

Be Strong.™



Model U916



Model R916

 **NAUTILUS** Service Manual
Commercial Series Bike

Model: U916 & R916

Important – Please Read

This manual is intended for authorized Nautilus or Nautilus certified service personnel and not for the consumer. There are no user serviceable parts. Servicing of the Nautilus® Commercial Series Bike by other than authorized Nautilus or Nautilus certified service personnel may result in voiding of the warranty.

If you are a consumer and require technical support to resolve a problem with your Nautilus® Commercial Series Bike, please call Nautilus® Customer Service at 800-628-8458 (North America) or +41-26-460-77-77 (outside North America).

Product Specifications	5	Cable Connections - U916.....	53
Important Safety Information	6	Cable Connections - R916.....	56
Safety Warning Labels	7	Appendixes	59
Maintenance	9	Required Tools.....	60
Maintenance Records	11	Using a Multimeter	61
Resetting the Maintenance Hour Timer.....	11	International Power Plug Configurations	64
Routine Maintenance.....	11	Warranty Information.....	65
Checking the Battery Charge.....	11	Contact Numbers	67
Recharging the Battery Back-up	12		
Battery Disposal.....	12		
Console Codes	13		
Overview.....	15		
Defaults	15		
Customize	15		
Machine Status	16		
Diagnostics.....	17		
Maintenance Logs.....	18		
Machine Configuration.....	20		
Electrical Troubleshooting	21		
U916/R916 Main Wiring Diagram	23		
U916 Console Heart Rate Wiring Diagram	24		
R916 Console Heart Rate Wiring Diagram	25		
General Bike Electronics Troubleshooting	26		
Mechanical Troubleshooting	35		
Removing/Replacing Parts - U916 and R916 Common Parts.....	37		
Removing/Replacing Parts - U916 Parts.....	48		
Removing/Replacing Parts - R916 Parts	51		

PRODUCT SPECIFICATIONS

	U916 Upright Bike	R916 Recumbent Bike	
Physical	Length	45 in. (114.3 cm)	67 in (170.18 cm)
	Width	24 in. (60.96 cm)	24 in. (60.96 cm)
	Height	57 in. (144.78 cm)	46 in. (116.84 cm)
	Workout Area	50" W x 81" L (127 cm x 205.74 cm)	50" W x 103" L (127 cm x 261.62 cm)
	Unit Weight	150 lb. (68 kg)	180 lbs (82 kg)
	Shipping Package Weight	178 lb. (81 kg)	231 lbs (105 kg)
	Max User Weight Supported	400 lb. (182 kg)	400 lb. (182 kg)
	Belt(s)	Two: Poly-V (6V) self-tensioning belt and timing belt	
Electrical	Power	Cordless; or 108-132VAC 60 Hz, or 220-240VAC 50 Hz, 20 watts maximum (operation with charger connected)	
	Battery Type	6VDC sealed lead-acid	
	Battery Charge Time	8 hours to full charge, starting with discharged battery	
	Display	C51 blue/white LCD with backlight. Tactile membrane keypad	
Functionality	Number of Functions	Eleven: Heart rate, elapsed time, calories burned, calories burned per hour, watts, METS, resistance level, rpm, speed, distance, and workout profile	
	Heart Rate Monitoring	Integrated heart rate monitoring system with polar-compatible wireless and contact HR	
	Workout Programs	Eleven: Quick Start, Manual, Fat Burner, Calorie Burner, Intervals, HR Zone Trainer, multi-stage Fit Test. Calorie Goal, HR Intervals, Random Play, Custom Intervals	
	Resistance Range	Twenty: 20 watts (level 1, 20 rpm) to 500 watts (level 20, 80 rpm)	
	Language Options	English, German, French, Spanish, Italian, Dutch, Portuguese	
	C-Safe Compatible	Level 2 compatible. Owner/manager will be able to customize console.	
Environmental	Operating Temperature	50–90 °F (10–32 °C)	
	Storage Temperature	-25–50 °C	
	Operating Humidity (non-condensing)	3–95% relative humidity	
	Storage Humidity (non-condensing)	3–95% relative humidity	

SAFETY REQUIREMENTS

IMPORTANT SAFETY INFORMATION: *SAVE THESE INSTRUCTIONS*

The following definition applies to the word “Warning” found throughout this guide:



WARNING

- Indicates a potentially hazardous situation which, if not avoided, could result in death or serious injury.



WARNING

**THIS SYMBOL APPEARING THROUGHOUT THIS MANUAL MEANS
PAY ATTENTION! BE ALERT! YOUR SAFETY IS INVOLVED!**



1. Read, understand and carefully follow all warnings, instructions and procedures in this manual. Failure to do so can produce a serious electrical shock hazard or other serious injury.
2. The external power supply should always be unplugged from the AC wall outlet before removing or installing parts. Never make adjustments or repairs while an exercise program is in progress.
3. Close supervision is necessary whenever the machine is being used or serviced whenever children, invalids, or disabled persons are in the vicinity.
4. Keep hands away from all moving parts. Keep feet on the pedals while exercising or testing the machine.
5. Do not operate the machine with the side covers removed, or outdoors.
6. Use this machine only for its intended use as described in this Manual. Do not use parts, attachments, or accessories other than those provided by Nautilus, Inc.
7. Do not use the external power supply if it has a damaged cord or plug, it is not working properly, if it has been dropped or damaged, or dropped in water. Contact our Technical Service Department to arrange for the return of damaged parts.
8. To avoid potential safety and electrical problems, replace with manufacturer’s specified parts only.
9. Connect the external power supply to a properly grounded AC wall outlet.
10. Keep all cords away from heated surfaces.
11. To disconnect the external power supply, remove the plug from the AC wall outlet.
12. Do not let liquid enter the console. If liquid does enter the console, the console must be inspected and tested for safety by an approved technician before it can be used again.
13. Never drop or insert any object into any opening on the machine.
14. Keep the area underneath and around the machine clear.
15. Do not operate where aerosol (spray) products are being used.
16. Always wear insulated gloves when handling batteries.
17. Do not crush, incinerate, or dismantle the battery.
18. The safety level provided by the design of this equipment can only be maintained when the equipment is regularly examined for damage and wear. Inoperable components should be replaced immediately or the equipment be put out of use until it is repaired.
19. Failure to follow the guidelines may compromise the effectiveness of the exercise experience, expose you (and possibly others) to injury, and reduce the longevity of the machine. Follow all training instructions listed in the manual and/or on the machine.

**THE ELECTROLYTE CONTAINS SULFURIC ACID, WHICH CAN
CAUSE SERIOUS DAMAGE TO EYES AND SKIN. SHOULD
THIS OCCUR, FLUSH PROFUSELY WITH WATER
AND SEEK MEDICAL ATTENTION.**

Failure to follow the conditions set forth below shall limit, to the extent allowed by law, Nautilus, Inc. responsibility for the safety, reliability, and performance of this equipment.

- The operator manual must be read in full by each owner and trainer before the product is first used. Each user must be instructed in the proper use of the bike and its accessories.
- The equipment must be used in accordance with the instructions for use.
- Only Nautilus-trained or Nautilus-authorized personnel should carry out assembly operations, extensions, readjustments, modifications, or repairs.
- For further information or instruction on use, maintenance or specifications, please contact your Authorized Nautilus Fitness Dealer or Service Technician.

SAFETY WARNING LABELS

The following safety warnings are located on the Nautilus® Commercial Series Bike. Please read all safety precautions and warning information prior to using your product. Be sure to replace any warning label if damaged, illegible, or missing. If you need replacement labels, please call a Nautilus Representative at (800) 628-8458 (North America) or +41-26-460-77-77 (International office).

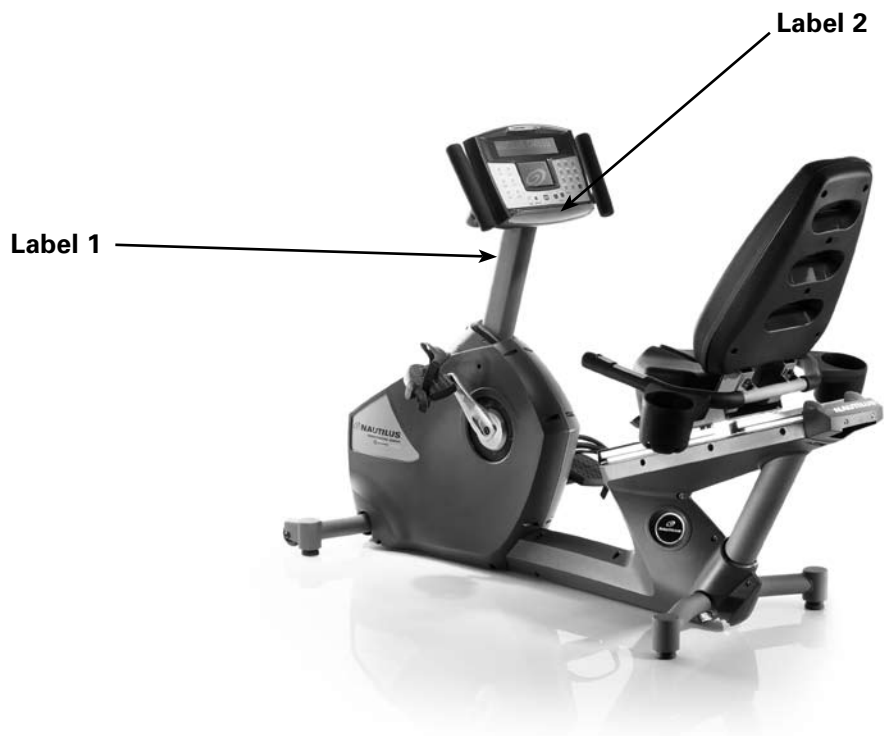

SAFETY WARNING LABELS

The following safety warnings are located on the unit. Please review and understand the safety warning labels and their locations on the unit prior to use.

If you do not have, or cannot find, or need to replace a warning label please call 1-800-628-8458 (North America) or +41-26-460-77-77 (International office) to obtain a new label.

Label 1: See Figure 1 for general warning label.

Location: The warning label in Figure 1 is located on the side of the console mast.

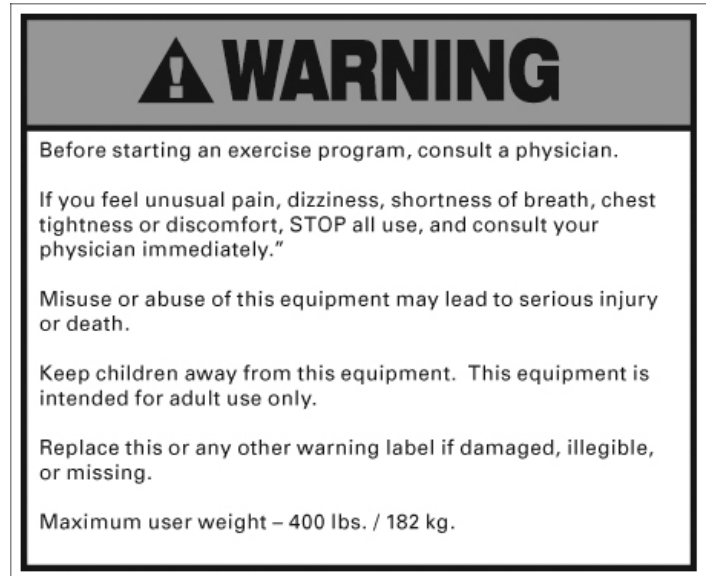

Figure 1

Label 2: See Figure 2 for general exercise warning label.

WARNING: If you have not been exercising regularly consult a physician before starting an exercise program. If you feel any unusual pain, dizziness, or shortness of breath, STOP. Consult a physician.

Figure 2

Location: Affixed to the console face below the keypanel.

1

Maintenance

Contents

Maintenance Records	11
Resetting the Maintenance Hour Timer	11
Routine Maintenance.....	11
Checking the Battery Charge	11
Recharging the Battery Back-up	12
Battery Disposal.....	12

Maintenance Records

For ease of maintenance the U916 and R916 console will keep track of hours, number of workouts, time between last servicing, etc. You can quickly access any of the custom menus by pressing [LEVEL: UP], [4], [ENTER]. The console will then display "MACHINE STATUS." Use the [Level: UP] and [Level: DOWN] keys to scroll through the options. For details, refer to the Machine Status Console Codes.

Resetting the Maintenance Hour Timer

After each maintenance period reset the counter. Press [LEVEL: UP], [7], [ENTER]. Then use the Level keys to scroll through the options. When "MAINT HOURS" is displayed, press [ENTER]. Press the [0] key, then press [ENTER]. Press [CLEAR] to return to the opening screen.

Routine Maintenance

Upon receiving your machine, use a soft, clean towel to wipe off the dust, which may have accumulated during shipping. Your new machine will require minor assembly. Refer to the "Installation Instructions" section for details.

Cleaning

1. DO NOT USE GLASS CLEANERS OR ANY OTHER HOUSEHOLD CLEANERS ON THE CONSOLE. Clean the console daily with a water-dampened cloth and wipe dry after cleaning.
2. Clean the exterior of the machine daily using soap and water or a diluted, non-mineral based household cleaner such as Fantastic®.

Inspection

1. **Frame:** Inspect the frame for any rust, bubbling, or paint chips during the weekly cleaning. The salt in perspiration can damage the unpainted surfaces. Repair the damaged area with a touch-up paint kit purchased from Nautilus (call Customer Service for order information).

Checking the Battery Charge

1. Using your multimeter, touch the red lead to the positive terminal of the battery and the black lead to the negative terminal.
2. If the voltage level is less than 6.1 VDC, charge the battery.

Recharging the Battery Back-Up

The Commercial Series U916 and R916 bikes are both self-powered (cordless) with a rechargeable battery back-up. Typically, the bike can be operated without plugging in the battery charger. If, however, the console flickers during operation or the console display does not light up while using the machine, then use the battery charger to recharge the battery back-up.

The battery charger is supplied with the unit and plugs into a standard 115 volt, 15 amp outlet, or a 220 volt, 15 amp outlet. (All major voltage plugs are available.) The plug-in for the battery charger is located in the front of the machine at the base.

NOTE: If installing the optional LCD Monitor, refer to the NV915 installation manual at this time.

Plug the wall pack battery charger into the connector and charge the battery for approximately 24 hours and then recheck it. It is okay to use the machine while the battery charger is connected.

When the bike is not connected to an external power source, the console will power on as the user starts to pedal machine, and will stay lit for up to 60 seconds in pause mode. The console will power off after 60 seconds of stopping exercise.

If the bike is connected to an external power source, the console will power on automatically and stay on until power is disconnected.



Battery charger plug-in

Battery Disposal

When ordering new batteries, you will need to properly dispose of (recycle) your old lead-acid batteries. Most federal and state regulations require lead-acid batteries to be recycled. Do not throw away old batteries. Lead is a toxic heavy metal, hazardous to living organisms. Disposal instructions and a list of recycling centers are tabulated in the Appendix. If you have questions, contact the Customer Service Department at 800-628-8458 (North America) or +41-26-460-77-77 (International office).

2

Console Codes

Contents

Overview	15
Defaults.....	15
Customize.....	15
Machine Status.....	16
Diagnostics.....	17
Maintenance Logs.....	18
Reset Maintenance Hours.....	19
Error Log.....	19
Machine Configuration.....	20

Overview

To enter a Service Mode, the unit must be in IDLE DISPLAY state or an ERROR. The service screens cannot be entered during a workout, paused or in a WARNING state. (If the unit is in a Warning state, you must press [CLEAR] before entering the Service Modes.) To access the console codes, press the Level Up button (▲), the group number code, and [ENTER]. Then use the arrow buttons to scroll through the menu options for each group. The procedures are outlined in the tables below.

There are six groups of Service Mode console codes: Defaults (codes starting with 2), Customize (codes starting with 3), Machine Status (codes starting with 4), Diagnostics (codes starting with 6), Maintenance Logs (codes starting with 7), and Change Machine (codes starting with 8). Each group of codes is defined below.

Defaults

You can customize several workout parameters on the R916/U916 Bike with default values to conform to your individual requirements, including:

- % target heartrate (10-90%)
- age (10-99)
- workout time (5-99 min)
- workout level (1-20)
- weight (50-400 lbs. or 25-180 kg)

Refer to the following table to scan through and customize the settings:

Table 2–1. Defaults

Step No.	Press Keys	Display (What you will see)
1	▲, 2, ENTER	DEFAULTS
2	▼ or ▲	CHR PERCENT, AGE, TIME, LEVEL, WEIGHT
3	ENTER	Selected choice
4	▼ or ▲ (or numeric keypad)	Default value changes
5	ENTER	DEFAULTS
6	CLEAR	SELECT WORKOUT

Customize

You can customize several console settings on the R916/U916 Bike with default values to conform to your individual requirements, including:

- resetting all configurable settings to factory defaults (see below)
- adjusting lower screen contrast (0-15)
- adjusting upper screen contrast (0-15)
- console language
- choosing type of heartrate inputs (description below)

Machine Status

- change units (USA units or metric units)
- cooldown time (1-10 min)
- maximum time limit (10-99 min or OFF)

Refer to the following table to scan through and customize the settings:

Table 2–2. Customize

Step No.	Press Keys	Display (What you will see)
1	▲, 3, ENTER	CUSTOMIZE
2	▼ or ▲	SET DEFAULTS, CONTRAST ADJ LOWER, CONTRAST ADJ UPPER, LANGUAGE, SELECT STATS*, HR INPUTS, CHANGE UNITS, COOL DOWN, MAX TIME LIMIT
3	ENTER	Selected choice
4	▼ or ▲ (or numeric keypad)	Default value changes
5	ENTER	CUSTOMIZE
6	CLEAR	SELECT WORKOUT

*The SELECT STATS menu display option is not active for the R916 and U916.

Set Defaults – resets the machine to the factory defaults for all configurable values. Please note that selecting this option will require the machine to be reconfigured (see Change Machine section).

NOTE: All error and history counter data (Maint Hours, Distance, Workouts, Run Hours, Error Log, and QA ID Number) will be lost if Set Defaults is selected.

HR Inputs – enables the various heart rate inputs that can be used. Heart rate configurations include: Locked Inputs (both heart rate monitors are read until it detects a valid signal to lock on, at which point the other HR inputs are ignored), HAND HR PRGM OFF, Both HR OFF, Hand Only, Telemetry Only, and Either Input (if one input is lost, then the other input may become active).

Change Units - changes all displayed data (service information and user data) to the selected units. Units are: Miles or Kilometers, MilesPerHour or KilometersPerHour, Pounds (LB) or Kilograms (KG), MinutesPerMile or MinutesPerKM.

Machine Status

Use the machine status codes to view maintenance information such as:

- maintenance hours
- machine type (U/R916)
- console software version
- distance traveled
- number of workouts
- machine run-time hours

Refer to the following table to scan through and customize the settings:

Table 2–3. Machine Status

Step No.	Press Keys	Display (What you will see)
1	▲, 4, ENTER	MACHINE STATUS
2	▼ or ▲	MAINT HOURS, U/R916 [or other], CONS, DISTANCE, WORKOUTS, RUN HOURS
3	CLEAR	SELECT WORKOUT

Maint Hours – displays the number of hours (incremented every hour) the machine has been running. The start value is set under the Maintenance Logs service screen. (The start value can be set to any value—e.g. if the service tech had entered 100 in the Maintenance Logs service screen and there was 1 hour of running time on the machine, the value under this Maint Hours screen would read 101).

Machine Type – should display U/R916. “NTM Config REQD” appears on the console if the software has been updated on the machine or the machine froze up and the power had to be cycled. The message also appears when the console assembly has been replaced and no configuration established. Configuring the machine will eliminate this message (see the table “Machine Configuration”).

Distance – displays the total distance in miles (or kilometers) of machine operation. This value is auto-incremented every 1/100th or 1/10th unit, depending on how many miles/km have accrued.

Workouts – displays the total number of workouts performed on the machine. This value is auto-incremented only if the user enters a workout and either completes the workout or presses the [STOP] key twice.

Run Hours – displays the total number of hours on the machine.

NOTE: The R&D options (codes starting with 5) are not used for servicing machines. Do not change these settings. If an R&D setting is inadvertently changed, it will reset when the machine is powered off and then back on.

Diagnostics

Use diagnostic codes to test various components of the machine such as the:

- tachometer
- alternator
- I/O
- sensor (for EV9.16 only)
- serial ports
- keypad
- display

Maintenance Logs

Refer to the following table to scan through the diagnostic tests and view diagnostic information:

Table 2–4. Diagnostics

Step No.	Press Keys	Display (What you will see)
1	▲, 6, ENTER	DIAGNOSTICS
2	▼ or ▲	TACH TEST, ALT TEST, I/O TEST, A SENSOR B, SERIAL PORTS, KEY TEST, DISPLAY TEST
3	ENTER	Selected choice
4	CLEAR	DIAGNOSTICS
5	CLEAR	SELECT WORKOUT

Tach Test – performs a tachometer test. On the left hand side of the display the target rate of 2000 rpm is displayed. On the right hand side of the display the actual rpm is displayed. If the actual rpm is above the target rate, then the alternator field turns on (the level increases). If the actual rpm is below the target rate, then the alternator field shuts off (the level decreases).

Alt Test – performs an alternator test. By pressing the level up key, the alternator field will turn on and the steps will become harder to rotate. By pressing the level down key, the alternator field will turn off and the steps will become easier to rotate.

I/O Test – The AUX and B+ values represent the current and voltage delivered from the alternator respectively. AUX is scaled by 1000 and B+ is scaled by 300. These values will increase with the speed of the alternator (note that both values will reach 0 if the alternator is left at rest). The "---" string is displayed at all times since the bikes do not require a magnetic key.

A Sensor B – is used only on the ellipticals. The A Sensor B diagnostic screen ensures the optical detector is functional. The A value is displayed on the left hand side of the upper display (B is not used on the EV9.16). Under normal conditions, the A value should toggle between the "0" and "1".

Serial Ports - tests the serial ports (UARTS) for proper functionality. The tech can choose from either the CSAFE-1 Loopback or TM Loopback tests. Both of these tests result in PASS or FAIL. Please note that a null modem must be used to perform these tests.

Key Test - tests all of the user interface keys. Once a key is pressed, its value will show up on the display screen. After all keys have been pressed and are functional, a PASS message appears on the display.

Display Test - will test all segments on both the top and bottom displays.

Maintenance Logs

The MAINTENANCE LOGS settings allow you to view the quality assurance data, the machine's error log, and reset the time between service and maintenance calls.

Refer to the following table to scan through the Maintenance Logs tests and view diagnostic information:

Table 2–5. Maintenance Logs

Step No.	Press Keys	Display (What you will see)
1	▲, 7, ENTER	MAINTENANCE LOGS
2	▼ or ▲	QA ID NUMBER*, MAINT HOURS, ERROR LOG
3	ENTER	Selected choice
4	CLEAR after viewing (or reset)	MAINTENANCE LOGS
5	CLEAR	SELECT WORKOUT

* The QA ID NUMBER option is not used for servicing machines in the field.

The following tables provide the steps for resetting the time between service or maintenance calls, and for viewing the error log:

Table 2–6. Reset Maintenance Hours

Step No.	Press Keys	Display (What you will see)
1	▲, 7, ENTER	MAINTENANCE LOGS
2	▼, ▼	MAINT HOURS
3	ENTER	MAINT HOURS ####
4	CLEAR to exit after viewing, or 0, ENTER to reset	MAINTENANCE LOGS
5	CLEAR	SELECT WORKOUT

Maint Hours – lets the service technician enter a value representing the maintenance hours.

Table 2–7. Error Log

Step No.	Press Keys	Display (What you will see)
1	▲, 7, ENTER	MAINTENANCE LOGS
2	▼, ▼, ▼	ERROR LOG
3	ENTER	NO ERROR or the highest priority error
4	▼ or ▲	Scrolls through the error log list
5	CLEAR	SELECT WORKOUT

Error Log – displays fatal errors accrued on the system. The log holds up to 8 error entries. Errors are handled in two ways:

- First, as a non-fatal Warning, which will display the error response text but continue system operation until you press the [CLEAR] key. Warnings are not logged in the Error Log.
- The second way is a fatal Error, which will stop the exercise and return the system to an idle intensity state. The console will display the error response and a number showing how many errors were logged during the specific event. (Some errors trigger multiple responses). To view the non-displayed errors, access the Error Log. The unit will not let you restart the program unless power has been turned off and then back on.

Machine Status

Once you access the Error Log, you can cycle the display through 8 entries by using the up/down keys. Each entry displays the error label, its position in the log (1-8), and the time (hours) the error occurred. Note that the most recent error might not be in log position 1—as the number of errors exceeds 8, the newest error will overwrite the oldest. In addition, if a new error is identical to the log's previous entry, the system checks the time. If the time is the same (within minutes), the error is not logged, to help prevent redundant errors.

The only way to reset the Error Log is to reconfigure the machine.

Machine Configuration

Use Machine Configuration to change the machine type. The choices are:

- Stepper
- StepMill
- U/R916
- Elliptical

In general, only the U/R916 machine type is used for the U916 or R916.

Refer to the following table to scan through and customize the settings:

Table 2–8. Machine Configuration

Step No.	Press Keys	Display (What you will see)
1	▲, 8, ENTER	CHANGE MACHINE
2	ENTER	U/R916
3	▼ or ▲	NTM CONFIG RQD, STEPPER CL, STEPMILL, ELLIPTICAL, U/R916
4	ENTER	Selects your choice
5	CLEAR	SELECT WORKOUT

NTM Config RQD – resets the machine to a “blank” configuration. The configuration must be set to Elliptical (or other machine type) for the workout functions to operate.

Stepper CL – configures the machine as a cordless Stepper. Please note that there is a sense line to let the software know if the system is a Stepper PT (corded); if the system is indeed a Stepper PT, then Stepper PT will appear in the screen instead of Stepper CL.

3

Electrical Troubleshooting

Contents

U916 and R916 Main Power Wiring Diagram.....	23
U916 Console Heart Rate Wiring Diagram	24
R916 Console Heart Rate Wiring Diagram	25
General Bike Electronics Troubleshooting.....	26
Contact Heart Rate Testing	28
Battery Charge Testing	29
Alternator Testing.....	30
Start-Up Circuit Testing	31
Load Resistor Testing	32
Shut-Down Testing	33

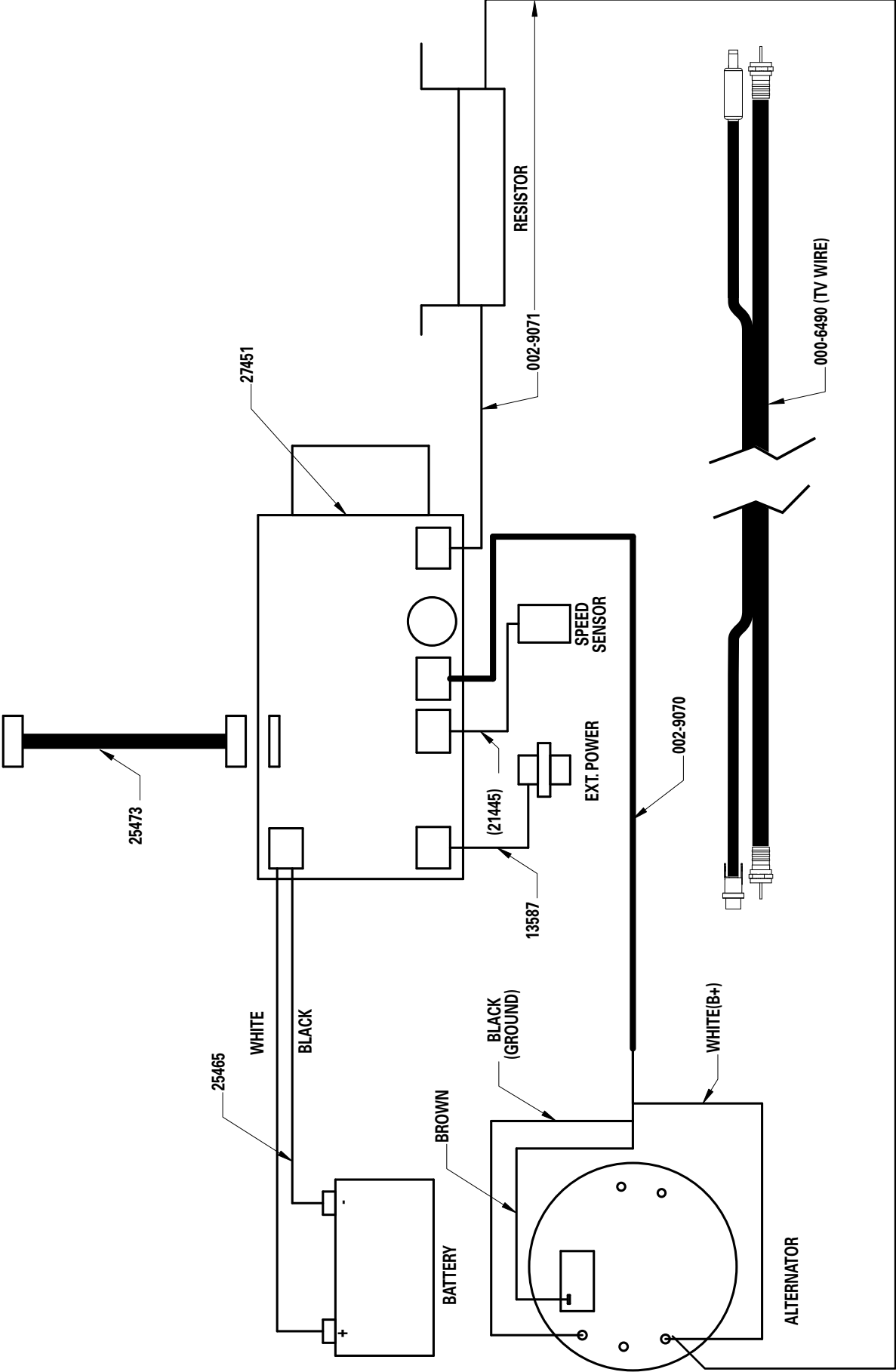

U916 and R916 Main Power Wiring Diagram

U916 Console Heart Rate Wiring Diagram

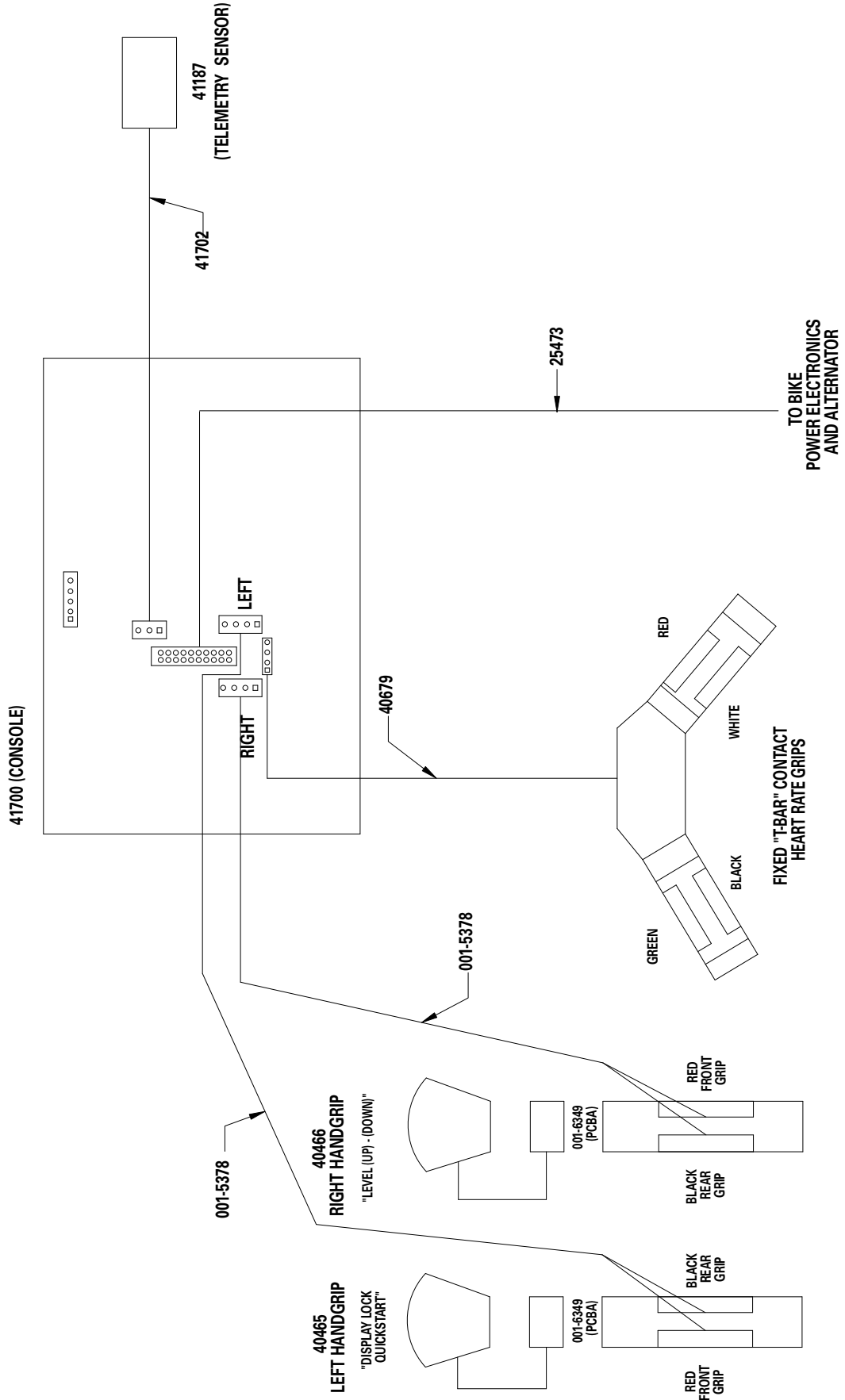

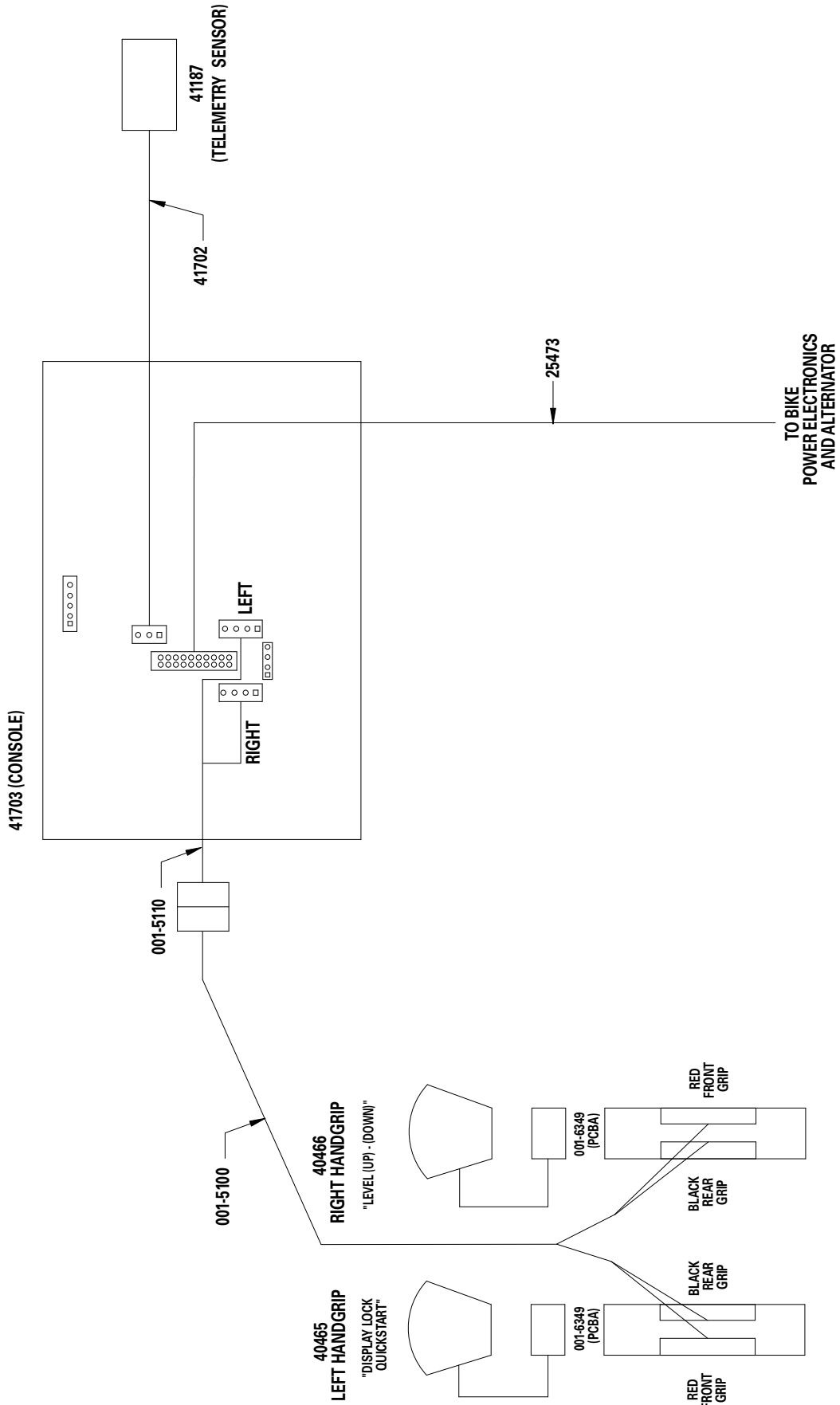

R916 Console Heart Rate Wiring Diagram

General Bike Electronics Troubleshooting

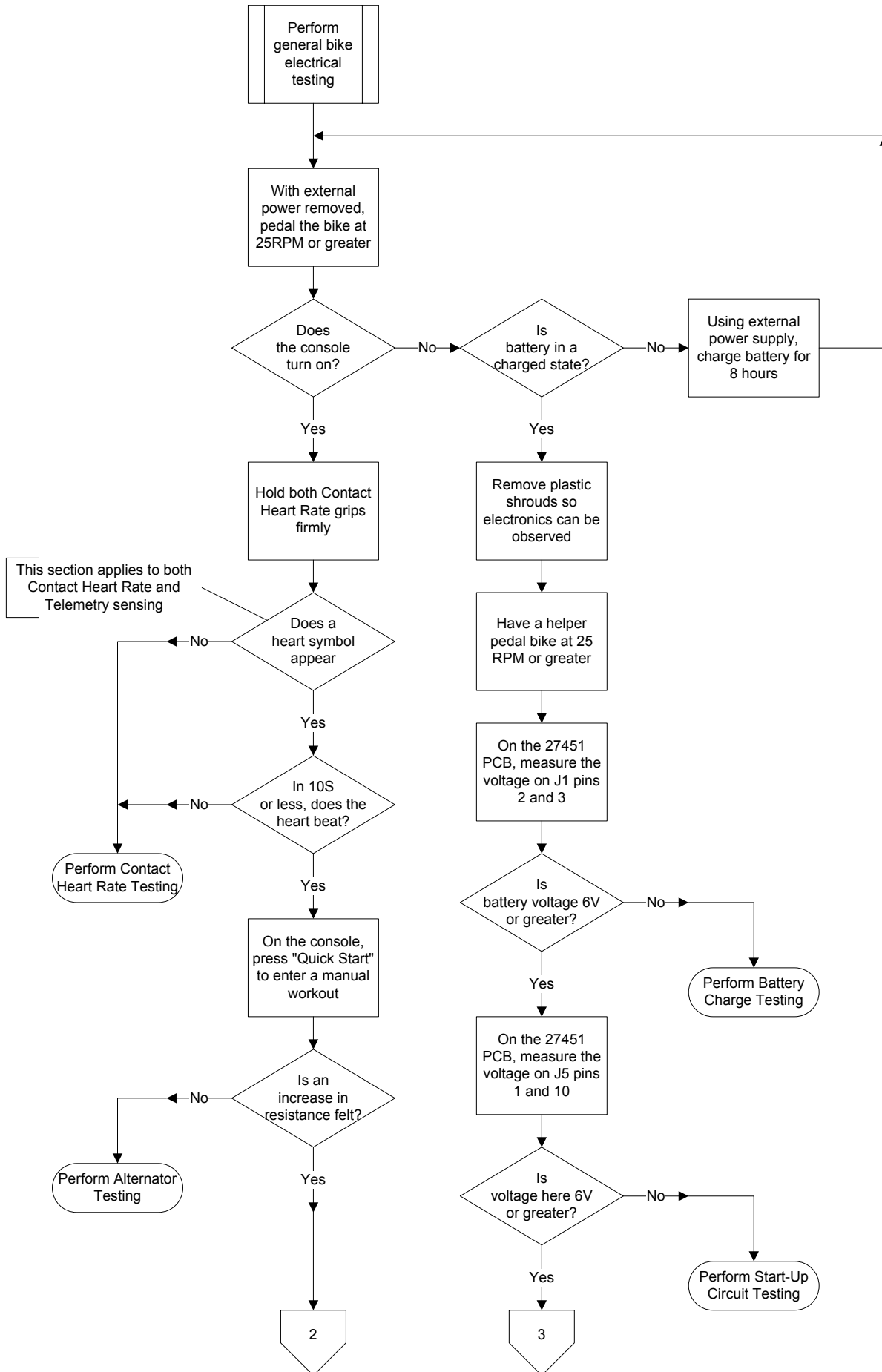

Continuation of General Bike Electronics Troubleshooting

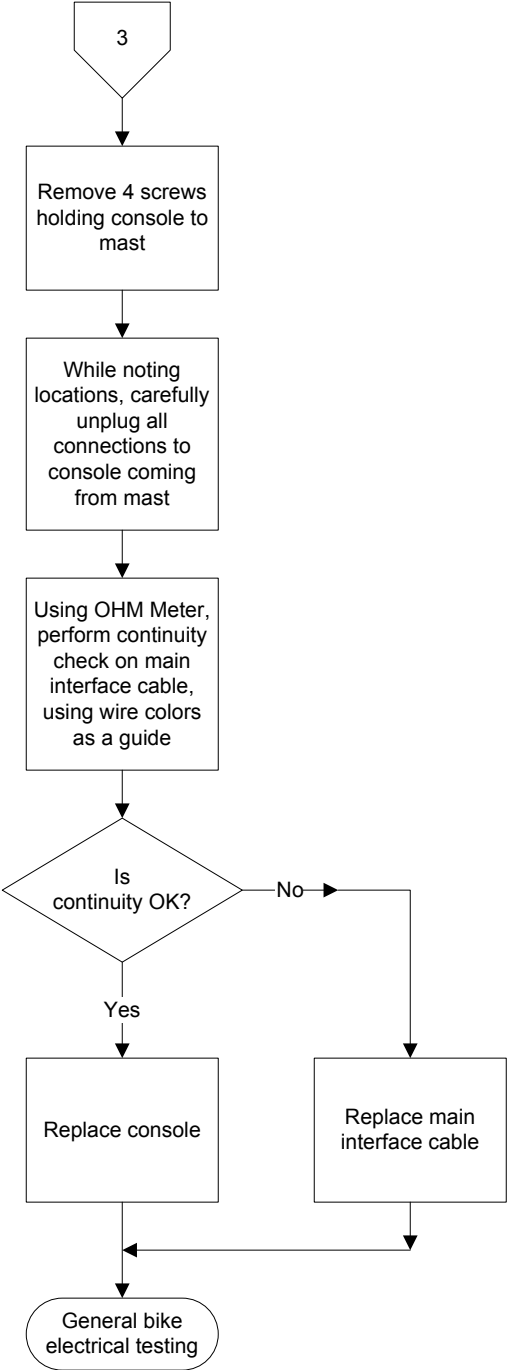
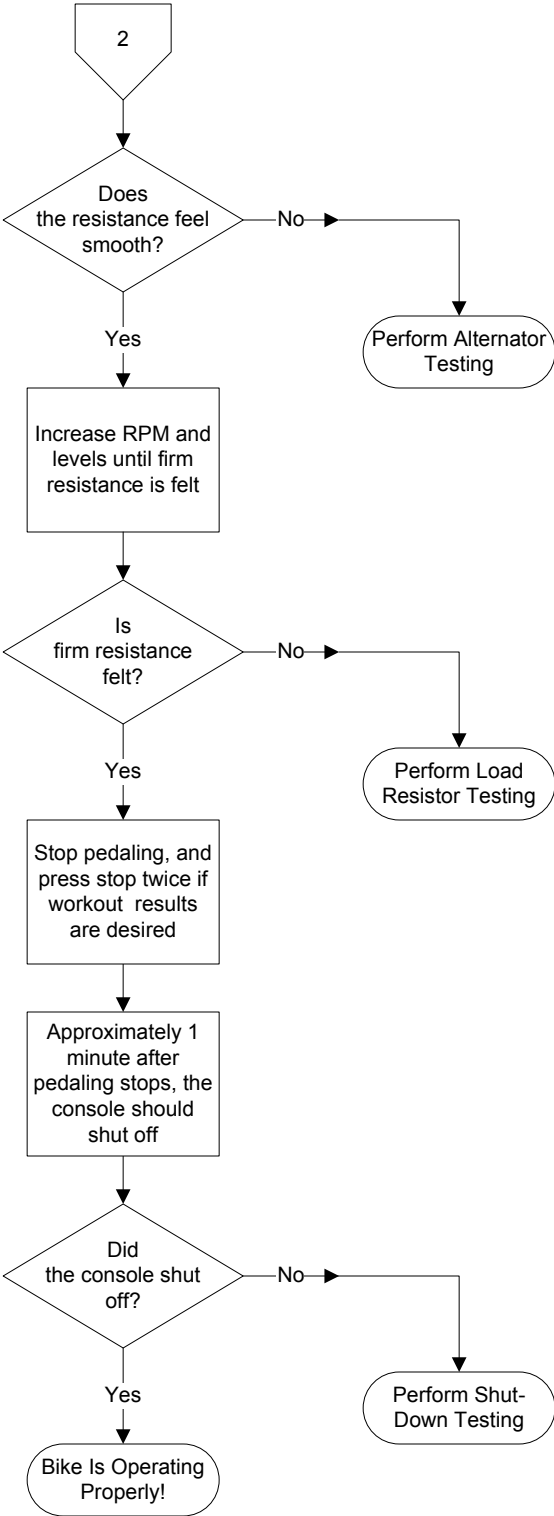

Contact Heart Rate Testing

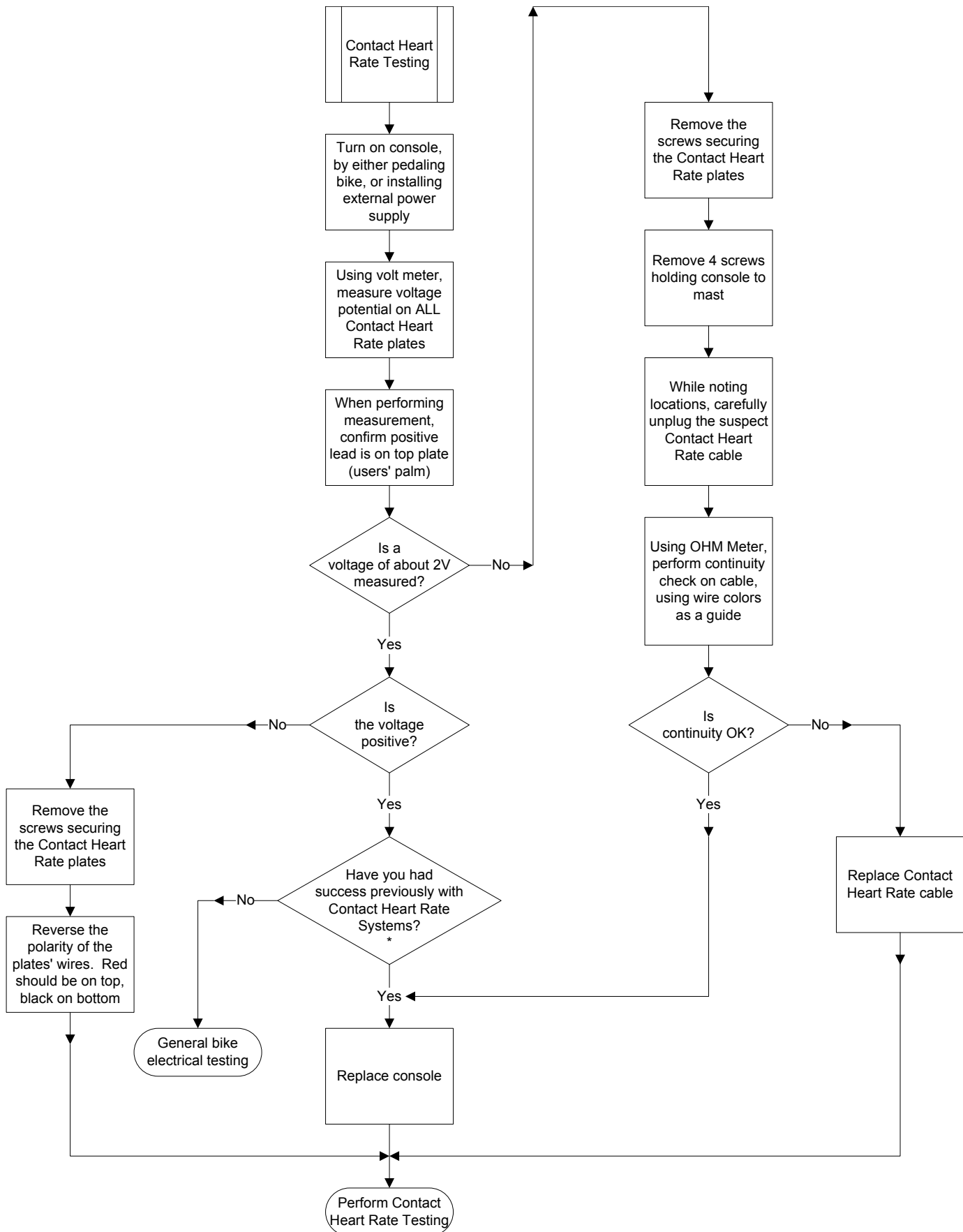

* Contact Heart Systems perform properly on roughly 87% of the population, according to latest data from Salutron. Many factors affect the pulse strength at the user's palms.

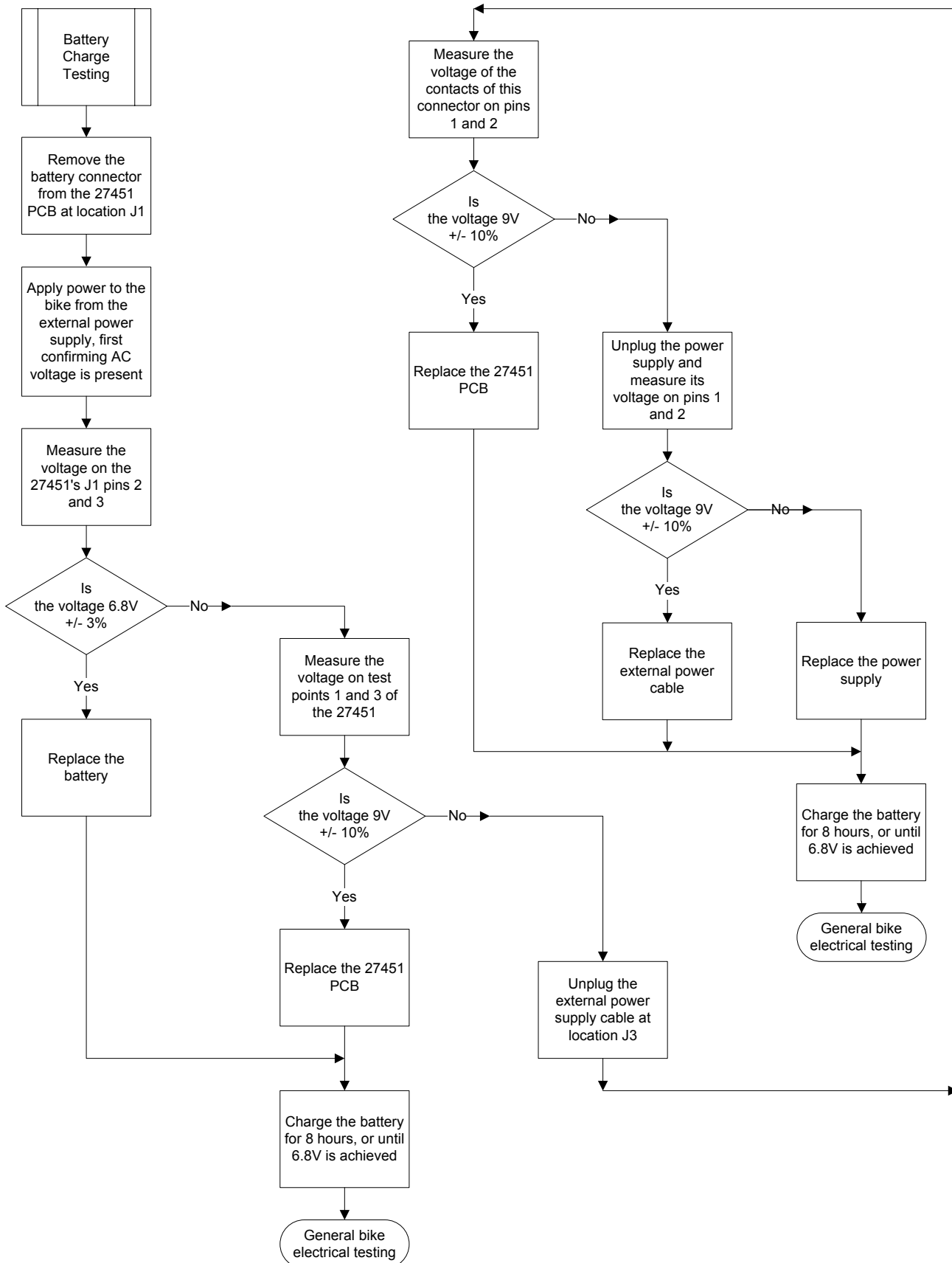

Due to requiring many pieces of test equipment, this procedure does not test the complete functionality of the charger but rather its final "float" state. If the battery voltage is less than 3V, no more than 50mA is applied. From 3V to 6.8V current control applies nearly .4A until voltage control or float state is entered. Batteries can only be tested under load. Even if it measures 6V or more unloaded, it can still produce little or no voltage under load as a defective battery's internal impedance increases.

Alternator Testing

To minimize the complexity of the flowchart, this section will best be described in terms of system theory.

The colored connections to the alternator are as follows:

White-B+ — Alternator output voltage

Brown-Field — Alternator Control Current

Black-Ground — Alternator return

Prior to proceeding with tests below, perform continuity checks on the alternator cable, and confirm cable is securely fastened to the alternator and the 27451 PCB.

For workouts that require levels of less than 50W resistance to the user, clinical mode must be used. In this condition, the console is powered by an external power supply, and the alternator is not powered unless the user decides to achieve levels of 50W or more.

If the bike's speed is 40 RPM or greater, and assuming clinical mode is not desired, the system can subject the user to a workout that is self-generating. Under self-generating conditions, the alternator is on; it is powering itself, the console, and providing charge to the battery.

Prior to entering workout information, it is desired to have the user subjected to minimal resistance, and the console is powered by the battery. Once the console knows all the user's desired information, it turns on the alternator. The alternator is turned on by a logic low on pin 2 of J5 of the 27451 PCB. This signal is also accessible on the 27451's TP11. Once the alternator is powered, the user sees an increase in resistance due to the alternator's internal magnetic fields.

The 27451 PCB maintains a regulated voltage on the alternator's B+ by varying the amount of current sourced into the alternator's field. B+ is sensed by the 27451, and the field current is altered until the alternator is at the desired voltage. As the RPM increases, the alternator's efficiency increases, and less field current is required.

Depending on the desired resistance level, the console can control the alternator's output voltage by controlling the logic level of pin 7 of J5 on the 27451 PCB. A logic low on pin 7 tells the 27451 to control at 7.8V or a logic high sets 9.8V.

If the alternator is not powering on, first confirm the bike is cranked at ~50 RPM, and that pin 2 of J5 (TP 11) is NOT high. If it is, and a workout has been entered, suspect the console. If pin 2 of J5 is low, measure the alternator's field voltage. Without B+ the 27451 will attempt to force full current into the field, and in this condition it will be limited by its input voltage, or the battery in this case. Therefore, if 5V or more is measured on the field with no B+, either B+ is shorted or the alternator is defective. Before replacing the alternator, disconnect the B+ wires from the alternator's B+ terminal and see if an output voltage exists. If voltage is now present, which could easily exceed 30V in an uncontrolled state, the 27451 PCB is probably defective. With no load on B+, 5V or more field current, adequate RPM and no B+, replace the alternator.

If no field voltage is detected, disconnect the B+ connections on the alternator, along with the field wire. Measure the field resistance to alternator ground, which should be approximately 4 ohms which is a typical value of Prestolite units. If the field resistance is way less than this or shorted, replace the alternator. If the field measures ~4 ohms, take a jumper wire, and make a connection from the positive battery terminal to the alternator's field tab. If the voltage now jumps up to a level of 20 to 30V the alternator is good, and the 27451 needs replacing.

If the B+ voltage is sporadic first look for loose connections. This type of problem could be caused by a defective alternator or 27451. If a known-good 27451 unit is available it will be the easiest component to replace. If the problem goes away, confirm the other PCB still causes sporadic behavior, and the problem was not in fact a loose connection.

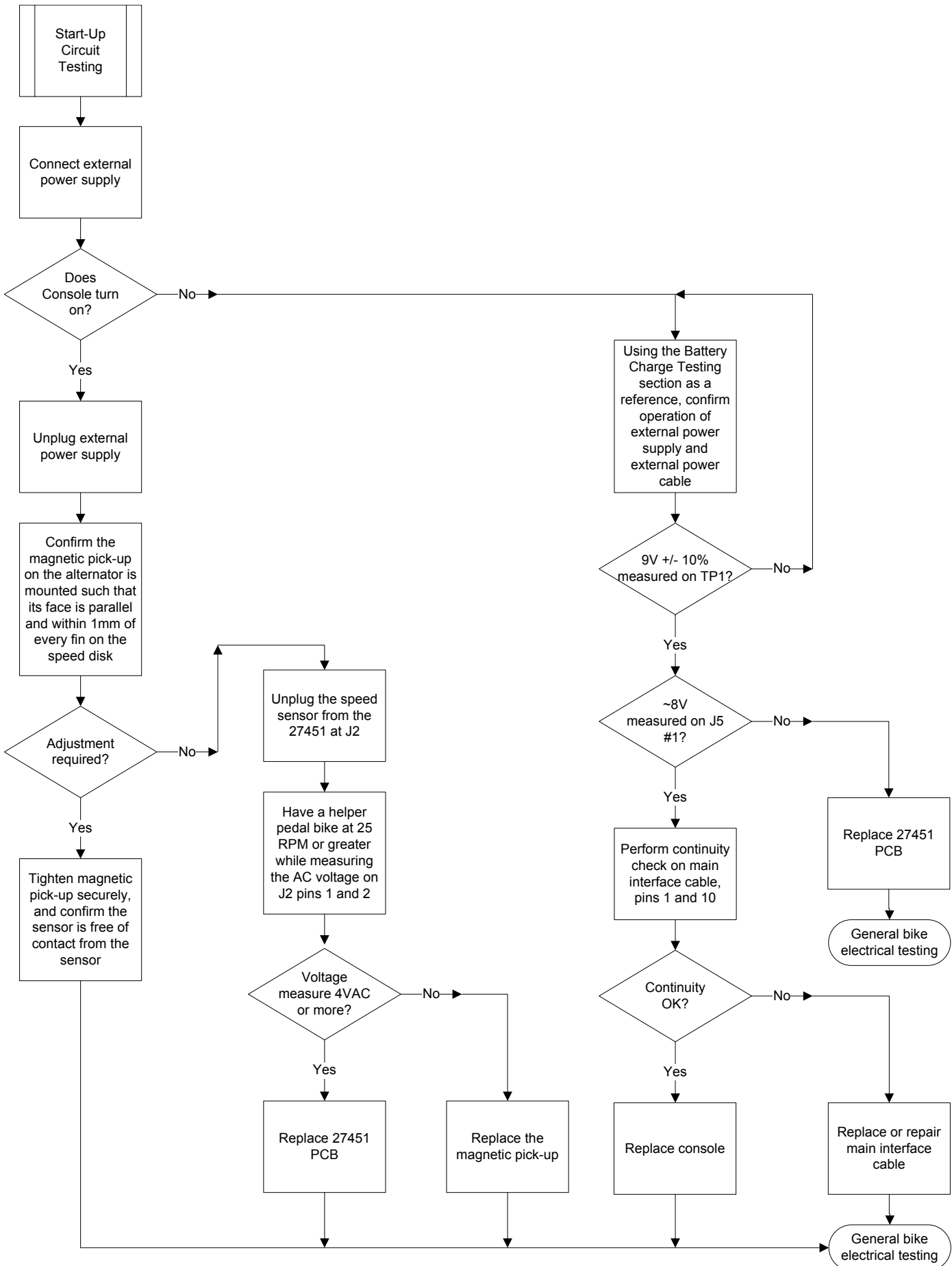

Load Resistor Testing

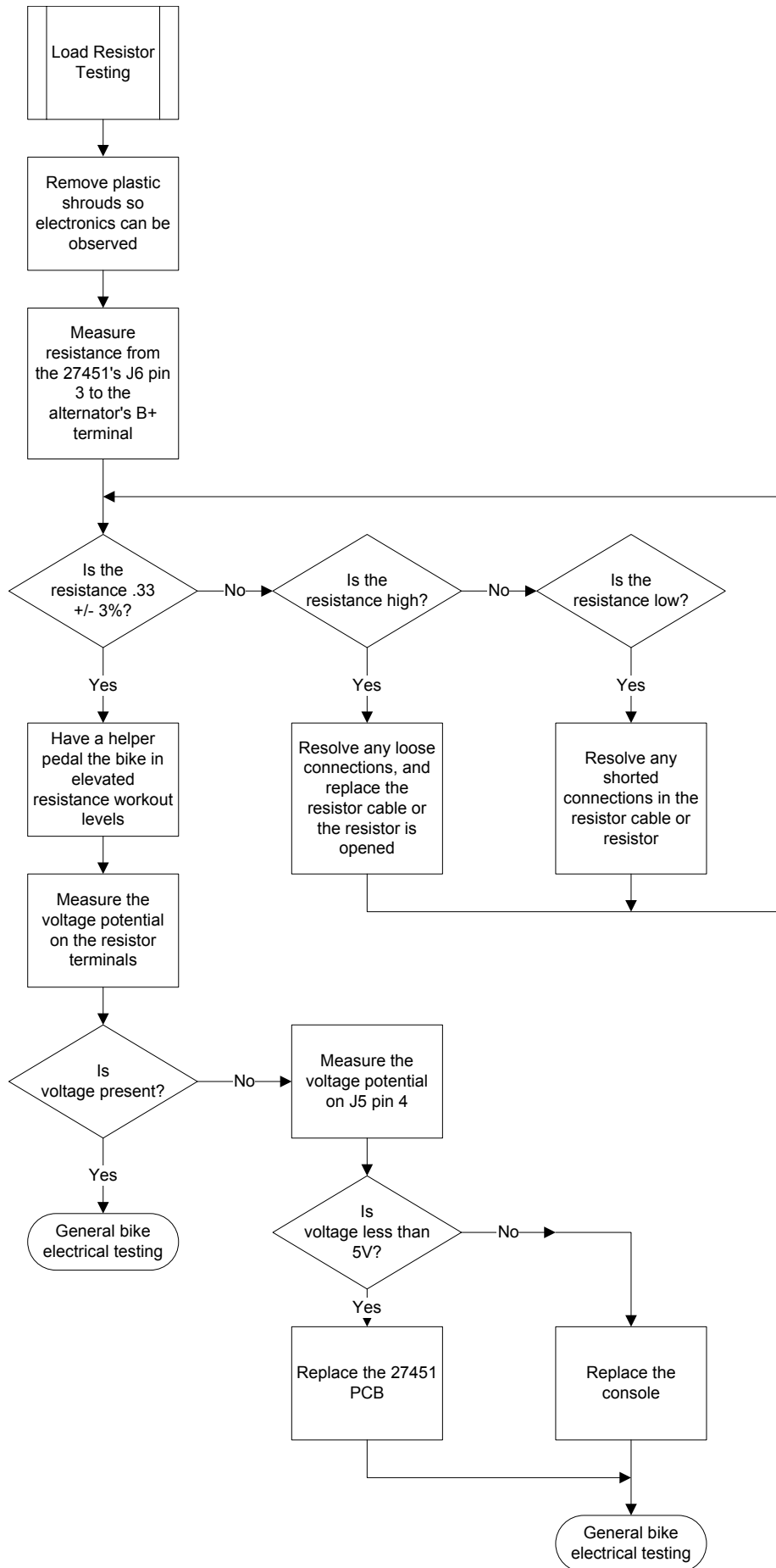

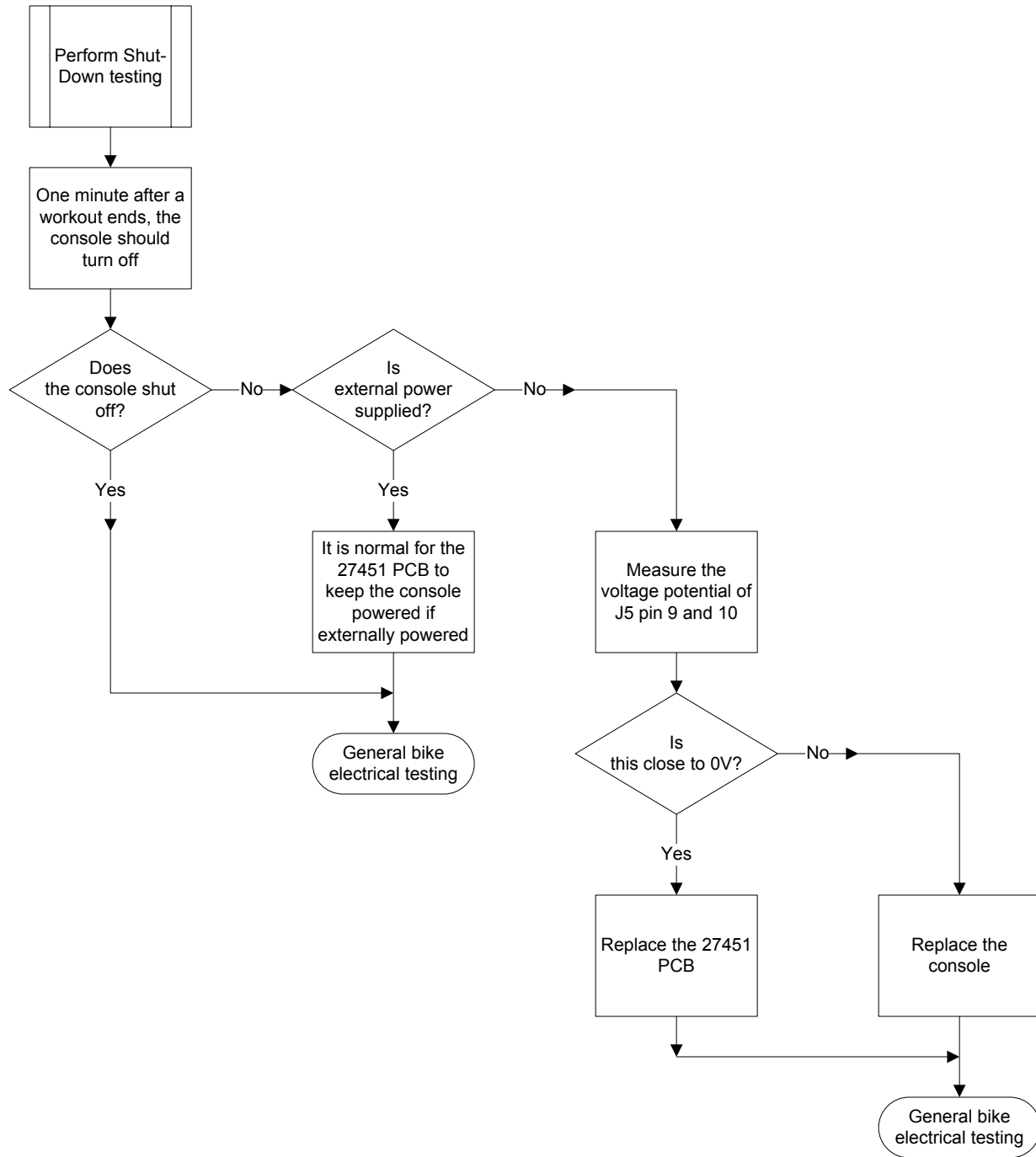

4

Mechanical Troubleshooting

Contents

Removing/Replacing Parts - U916 and R916 Common Parts	37
Removing the Console	37
Removing the Mast.....	38
Removing the Right and Left Pedals.....	39
Removing the Load Resistor	40
Removing the Battery	41
Removing the Power Board	41
Removing the Power Inlet Connector	42
Removing the Speed Sensor.....	43
Removing the Alternator.....	44
Removing the HTD Belt.....	46
Removing the Poly-V Wheel	47
Removing/Replacing Parts - U916 Parts.....	48
Removing the Upper Handle Bar	48
Replacing the Upper Right or Left CHR Plates	48

Replacing the Lower T-Bar Right or Left CHR Plates.....	49
Removing the Seat Assembly.....	50
Removing the Side Covers.....	50
Removing/Replacing Parts - R916 Parts.....	51
Removing the Side Covers.....	51
Removing the Left and Right Rear Covers.....	52
Cable Connections - U916.....	53
Cable Connections - R916.....	56

This section of the Service Manual provides instructions for removing and replacing parts of the U916 and R916 bikes. The first segment contains procedures that apply to both bike models. The second segment contains instructions specific to the U916 bike, and the third contains instructions specific to the R916 bike. The fourth segment focuses on the cable connections for the U916 and R916 bikes. For part number information, please refer to the separate documents for warranty parts lists and exploded drawings.

U916 and R916 Procedures

REMOVING THE CONSOLE:

Tools needed:

- Phillips screwdriver or Cordless drill with Phillips tip

Step 1: Remove the four Phillips screws attaching the Console to the Mast. See **Figure 1a** and **1b**.

Set the screws aside for Step 5.



Figure 1a - U916 console



Figure 1b - R916 console

Step 2: Tilt the console forward and disconnect all the cables from the Mast to the PC board connectors (**Figure 2**).

Note: Make note of each cable and the location of its connector on the PC board.

Step 3: Remove the Console.

Step 4: To replace the Console, position the Console at the top of the Mast so that you can connect the cables to the PC board (**Figure 2**). For specific connector locations, refer to the CABLE CONNECTIONS segment later in this section.



Figure 2 - Cable connections in back of Console (R916 console shown)

Mechanical Procedures

Step 5: Install the Console to the Mast using the four Phillips screws that you removed in Step 1. See **Figure 1a** and **1b**.

REMOVING THE MAST:

Tools needed:

Phillips screwdriver or Cordless drill with Phillips tip
6 mm Allen wrench
8 mm Allen wrench

Step 1: Remove the console according to the REMOVING THE CONSOLE procedure.

Step 2: For the U916 only – Remove the Upright Handlebar according to REMOVING THE UPPER HANDLE BAR procedure.

Step 3: Remove the right and left Mast covers with a Phillips screw driver. See **Figure 3a** and **3b**.

Step 4: For the U916 only – Remove the Cupholder from the Mast with a Phillips screwdriver (see **Figure 4**).

Step 5: Using a 8mm Allen wrench, remove the four bolts securing the Mast to the bottom half frame. See **Figure 5a** and **5b**.



Figure 3a - Remove right mast cover



Figure 3b - Remove left mast cover



Figure 4 - Remove cupholder (U916 only)



Figure 5a - Unbolt mast from frame (U916)

Step 6: Carefully lift and remove the Mast, allowing clearance so that the wires coming out the bottom are not pinched or scraped. See **Figure 6a** and **6b**.



Figure 5b - Unbolt mast from frame (R916)



Figure 6a - Lift mast off frame (U916)

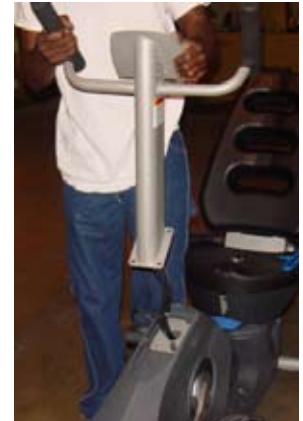

Figure 6b - Lift mast off frame (R916)

REMOVING THE RIGHT AND LEFT PEDALS:

Tools needed:
15mm Wrench

Step 1: Position yourself on the left side of the bike and place your left hand on the left pedal to stabilize it.

Step 2: Using a 15mm Wrench, turn the pedal nut clockwise to loosen and remove the left pedal (**Figure 7**).



Figure 7 - Loosen left pedal nut

Step 3: Position yourself on the right side of the bike and place your right hand on the right pedal to stabilize.

Step 4: Using a 15mm Wrench, turn the pedal nut counter-clockwise to loosen and remove the pedal (**Figure 8**).



Figure 8 - Loosen right pedal nut

Mechanical Procedures

REMOVING THE LOAD RESISTOR:

Tools needed:

Phillips screwdriver or Cordless drill with Phillips tip
5/16 Nut driver

Step 1: Remove the right and left side covers according to the appropriate REMOVING THE SIDE COVERS procedure (U916 or R916).

Step 2: Using a 5/16 Nutdriver and Phillips screwdriver, remove the hardware attaching the black and white wires of the Load Resistor cable from the tabs of the resistor. See **Figure 9a** and **9b**.

Step 3: Using a Phillips screwdriver, remove the two mounting screws attaching the Load Resistor to the frame (**Figure 10a**) and remove the resistor (**Figure 10b**).



Figure 9a - Detach resistor wires (U916)



Figure 9b - Resistor wires (R916)



Figure 10a - Unscrew resistor (U916 shown)



Figure 10b - Remove resistor (U916 shown)

REMOVING THE BATTERY:

Tools needed:

Phillips screwdriver or Cordless drill with Phillips tip
Wire cutters

Step 1: Remove the right and left side covers according to the appropriate REMOVING THE SIDE COVERS procedure (U916 and R916).

Step 2: Cut the cable tie holding the Battery in place (**Figure 11**).

Step 3: Disconnect the black and white Battery cable from the Battery. See **Figure 12**.

Step 4: Lift and remove the Battery (**Figure 13**).

REMOVING THE POWER BOARD:

Tools needed:

Phillips screwdriver or Cordless drill with Phillips tip

Step 1: Remove the right and left side covers according to the appropriate REMOVING THE SIDE COVERS procedure (U916 and R916)."

Step 2: Disconnect the attaching cables from Power board. See **Figure 14a** and **14b**.



Figure 11 - Cut cable tie



Figure 12 - Disconnect battery cable



Figure 13 - Remove battery



Figure 14a - Disconnect power board cables (U916 shown)

Step 3: Remove the four mounting screws at the corners of the Power board. See **Figure 15** (U916 shown).

REMOVING THE POWER INLET CONNECTOR:

Tools needed:

#0 Phillips screwdriver

Wire cutters

Step 1: Remove the right and left side covers according to the appropriate REMOVING THE SIDE COVERS procedure (U916 or R916).

Step 2: Disconnect the cable end of the Inlet connector from J3 on the Power board. See **Figure 16**.

Step 3: Cut the cable tie from the wire bundle to remove the cable. See **Figure 17**.

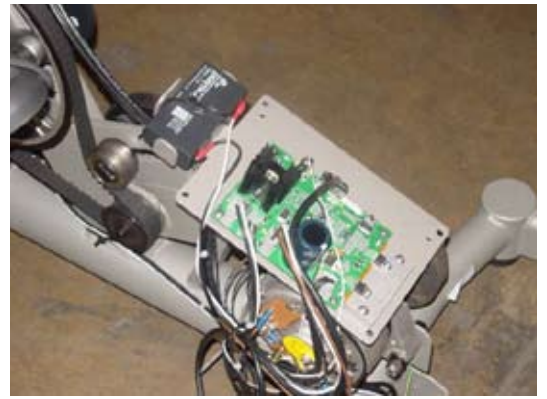

Figure 14b - Power board cables disconnected (R916 shown)

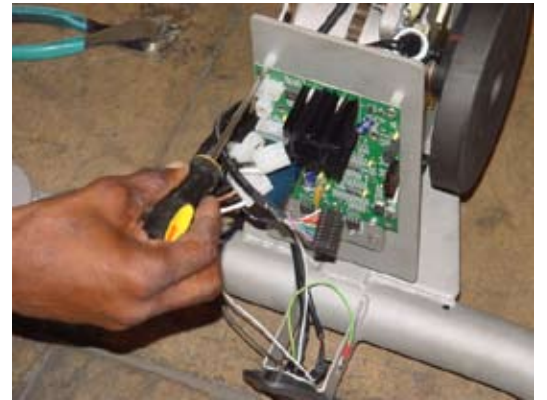

Figure 15 - Power board mounting screws



Figure 16 - Disconnect inlet connector cable

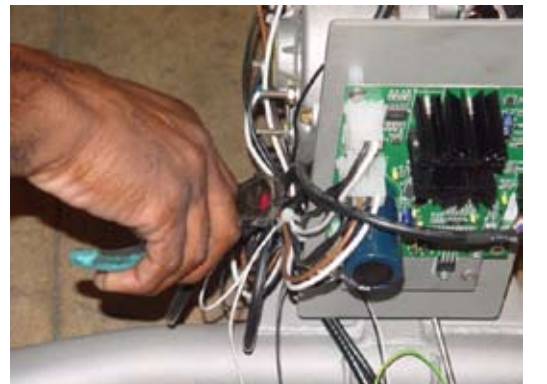

Figure 17 - Cut cable tie

Step 4: Remove the screw attaching the ground wire to the frame. See **Figure 18**.

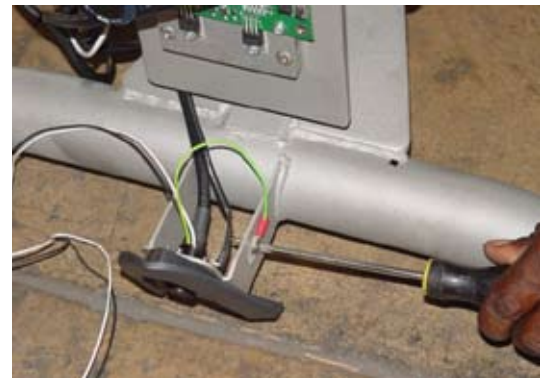

Figure 18 - Remove ground wire screw

Step 5: Using a #0 Phillips screwdriver, remove the four screws attaching the Power Inlet Connector to the frame and remove the connector. See **Figure 19a** and **19b**.



Figure 19a - Remove mounting screws

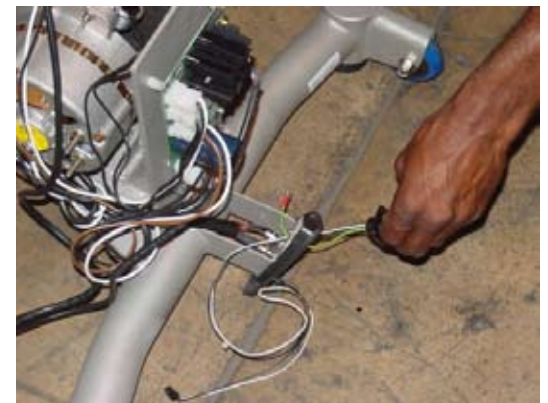

Figure 19b - Remove power inlet connector

REMOVING THE SPEED SENSOR:

Tools needed:

Phillips screwdriver or Cordless drill with Phillips tip
Wire cutters

Step 1: Remove the right and left side covers according to the appropriate REMOVING THE SIDE COVERS procedure (U916 or R916).

Step 2: Cut the cable tie from the wire bundle. See **Figure 20**.

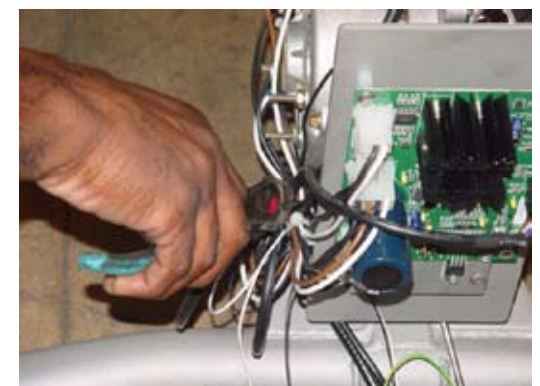

Figure 20 - Cut cable tie

Mechanical Procedures

Step 3: Disconnect the cable end of the Speed Sensor from J2 on the Power board and remove the wire from the bundle. See **Figure 21**.



Figure 21 - Disconnect speed sensor cable

Step 4: Loosen the adjustment screw and remove the Speed Sensor from the Alternator (**Figure 22**).

Note: Early model Speed Sensors are tightened with a screw adjustment. Later models are tightened with a nut and bolt.

When you (re)place the sensor on the Alternator, be sure the gap between the fan blade and the Sensor is .020 - .040.

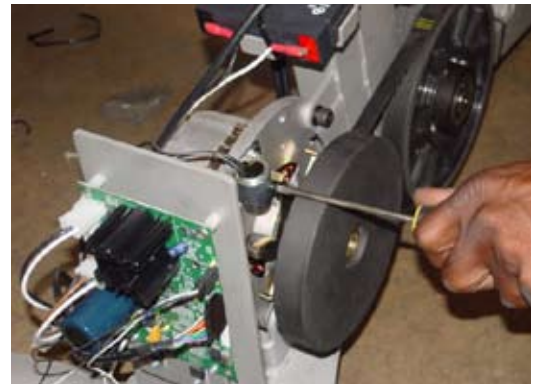

Figure 22 - Loosen adjustment screw

REMOVING THE ALTERNATOR:

Tools needed:

Phillips screwdriver or Cordless drill with Phillips tip

Wire cutters

Impact cordless wrench

15/16" socket and ratchet

6mm Allen wrench

8mm Allen wrench

9/16" socket

Step 1: Remove the right and left side covers according to the appropriate REMOVING THE SIDE COVERS procedure (U916 or R916).

Step 2: Remove all the attached cables from the Alternator, then detach the Speed Sensor from the Power board. See **Figure 23**.

Note: Make note of where and how the cables are attached to the Alternator.



Figure 23 - Detach all cables from alternator

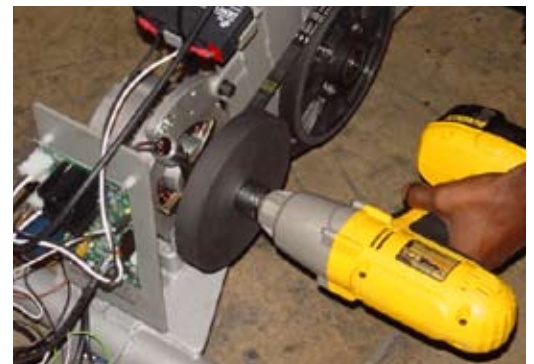

Figure 24 - Remove flywheel

Step 3: Using the 15/16 socket, remove the Flywheel nut with an Impact wrench or similar tool. See **Figure 24**.

Step 4: Remove the Alternator Poly-V belt by slowly “walking off” the belt in a clockwise motion (**Figure 25**).

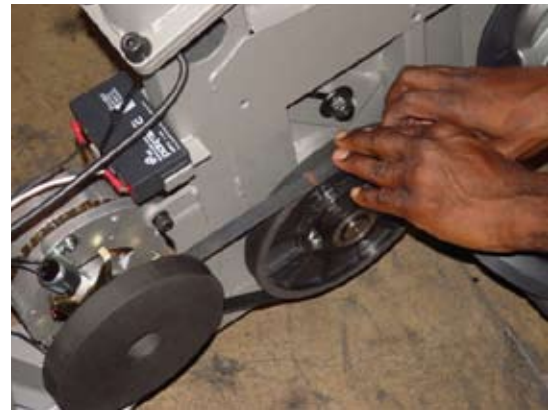

Figure 25 -

Step 5: Remove the Flywheel and Fan disk (**Figure 26**).



Figure 26 -

Step 6: Using a 6mm Allen wrench, 8mm Allen wrench, and 9/16 socket with ratchet, remove the two bolts that attach the Alternator to the frame. See **Figure 27a** and **27b**.

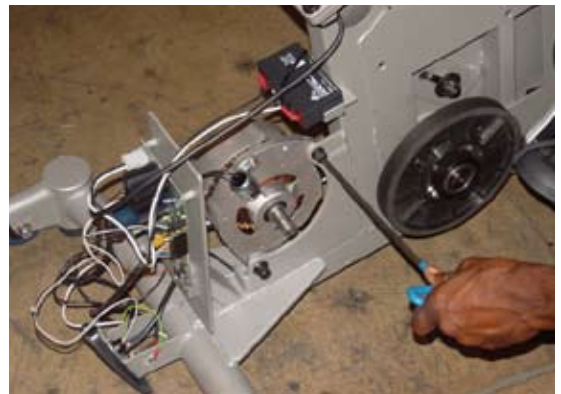

Figure 27a - Remove alternator mounting bolts

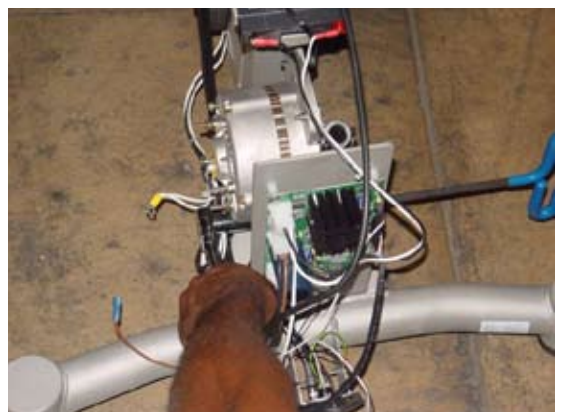

Figure 27b -

Step 7: Remove the Speed Sensor from the old Alternator according to the REMOVING THE SPEED SENSOR procedure, and install the Speed Sensor on the new Alternator. See **Figure 28**.

Note: When placing the sensor on the Alternator, be sure the spacing between fan blade and the Sensor is .020 - .040



Figure 28 -

REMOVING THE HTD BELT:

Tools needed:

- Phillips screwdriver or Cordless drill with Phillips tip
- 17mm Wrench
- 19mm Wrench

Step 1: Remove the Side covers according to the appropriate REMOVING THE SIDE COVER procedure (U916 or R916).

Step 2: Using a 17mm wrench and 19mm wrench, loosen the belt tensioner and slide upward along the slotted cut-out.

Note: Do not completely remove the screw. See **Figure 29a and 29b**.



Figure 29a - Loosen belt tensioner

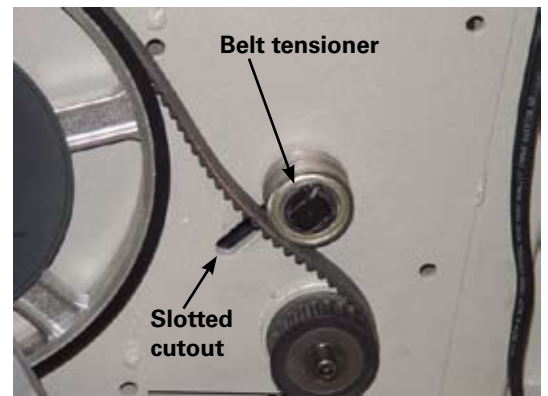

Figure 29b - Belt tensioner

Step 3: Remove the belt and place a new one on (**Figure 30**).



Figure 30 - Replace HTD Belt

REMOVING THE POLY-V WHEEL:

Tools needed:

Phillips screwdriver or Cordless drill with Phillips tip
 3/16 Allen wrench
 Snap ring pliers

Step 1: Remove the Side covers according to REMOVING THE SIDE COVER procedure for the U916 or R916.

Step 2: Remove the Alternator Poly-V belt by slowly “walking” the belt off the Poly-V wheel in a clockwise motion. See **Figure 31**.

Step 3: Using a 3/16 Allen wrench, loosen and remove the four mounting screws. See **Figure 32**.

Step 4: Remove the Snap ring (**Figure 33**) and pull off the Poly-V wheel.



Figure 31 -



Figure 32 -



Figure 33 -

U916 Procedures

REMOVING THE UPPER HANDLEBAR:

Tools needed:

Phillips screwdriver or Cordless drill with Phillips tip
6 mm Allen wrench

Step 1: Remove the console according to REMOVING THE CONSOLE procedure.

Step 2: Remove the four Allen screws attaching the Handlebar to the frame with a 6mm Allen wrench. See **Figure 34**.

Step 3: Carefully pull the cables out from the Mast (**Figure 35**).

Step 4: Reverse the steps to install a new Handlebar assembly on the machine.



Figure 34 -



Figure 35 -

REPLACING THE UPPER RIGHT OR LEFT CHR PLATES:

Tools needed:

#0 Phillips screwdriver

Step 1: Carefully remove the two screws from the rear CHR plate and separate the plates. See **Figure 36**.



Figure 36 -

Step 2: Disconnect the black CHR wire from the rear plate and place to the side. See **Figure 37**.



Figure 37 -

Step 3: Disconnect the cable wire connected to the PC board from the front plate. See **Figure 38**.



Figure 38 -

Step 4: Disconnect the red CHR wire from the front plate and place to the side. See **Figure 39**.

Step 5: Reverse the steps when reinstalling the plates.

Note: Be careful not to pinch the cable wires when reattaching the Front and Rear housings.



Figure 39 -

REPLACING THE LOWER T-BAR RIGHT OR LEFT CHR PLATES:

Tools needed:

#0 Phillips screwdriver

Step 1: Carefully remove the two screws from the rear CHR plate and separate the plates. See **Figure 40**.

Step 2: Disconnect the black CHR wire from the rear plate and place to the side.

Step 3: Disconnect the red CHR wire from the top plate and place to the side.

Step 4: Reverse the steps when reinstalling the plates.

Note: Be careful not to pinch the cable wires when reattaching the Front and Rear housings.



Figure 40 -

Mechanical Procedures

REMOVING THE SEAT ASSEMBLY:

Step 1: Press and hold the adjustment seat lever, then pull seat upward, straight out of the frame. See **Figure 41a** and **41b**.



Figure 41a -



Figure 41b -

REMOVING THE SIDE COVERS:

Tools needed:

Phillips screwdriver or Cordless drill with Phillips tip

Step 1: Position yourself on the left side of the bike, and remove the 13 phillips screws from the left side cover. See **Figure 42**.



Figure 42 -

Step 2: Position the left pedal so the cover may be carefully lifted and removed. See **Figure 43**.

Step 3: Position yourself on the right side of the bike and remove the two phillips screws from the bottom of the right side cover.

Step 4: Position the right pedal so the cover may be carefully lifted and removed.



Figure 43 -

R916 Procedures

REMOVING THE SIDE COVERS

REMOVING THE LEFT AND RIGHT FRONT COVERS:

Tools needed:

Phillips screwdriver or Cordless drill with Phillips tip

Step 1: Remove the six screws attaching the right and left Mast covers (**Figure 44**). Place the covers to the side.

Step 2: Position yourself on the left side of the bike, and remove the eight phillips screws from the left side cover. See **Figure 45**.

Step 3: Move the Seat Assembly back to the top position on the seat rail. Position the left pedal so the cover may be carefully lifted and removed. See **Figure 46**.

Step 4: Position yourself on the right side of the bike, and remove the one phillips screw located near the Mast from the right side cover. See **Figure 47**.



Figure 44 -



Figure 45 -



Figure 46 -



Figure 47 -

Mechanical Procedures

Step 5: Position the right pedal so the cover may be carefully lifted and removed. See **Figure 48**.



Figure 48 -

REMOVING THE LEFT AND RIGHT REAR COVERS:

Tools needed:

Phillips screwdriver or Cordless drill with Phillips tip

Step 1: Remove the left and right Front covers according to the REMOVING THE LEFT AND RIGHT FRONT COVERS procedure.

Step 2: Position yourself on the left side and remove the 13 Phillips screws from the side cover, then carefully lift and remove. See **Figure 49a** and **49b**.



Figure 49a -



Figure 49b -

Step 3: Position yourself on the right side and remove the three Phillips screws from the side cover, then carefully lift and remove. See **Figure 50**.

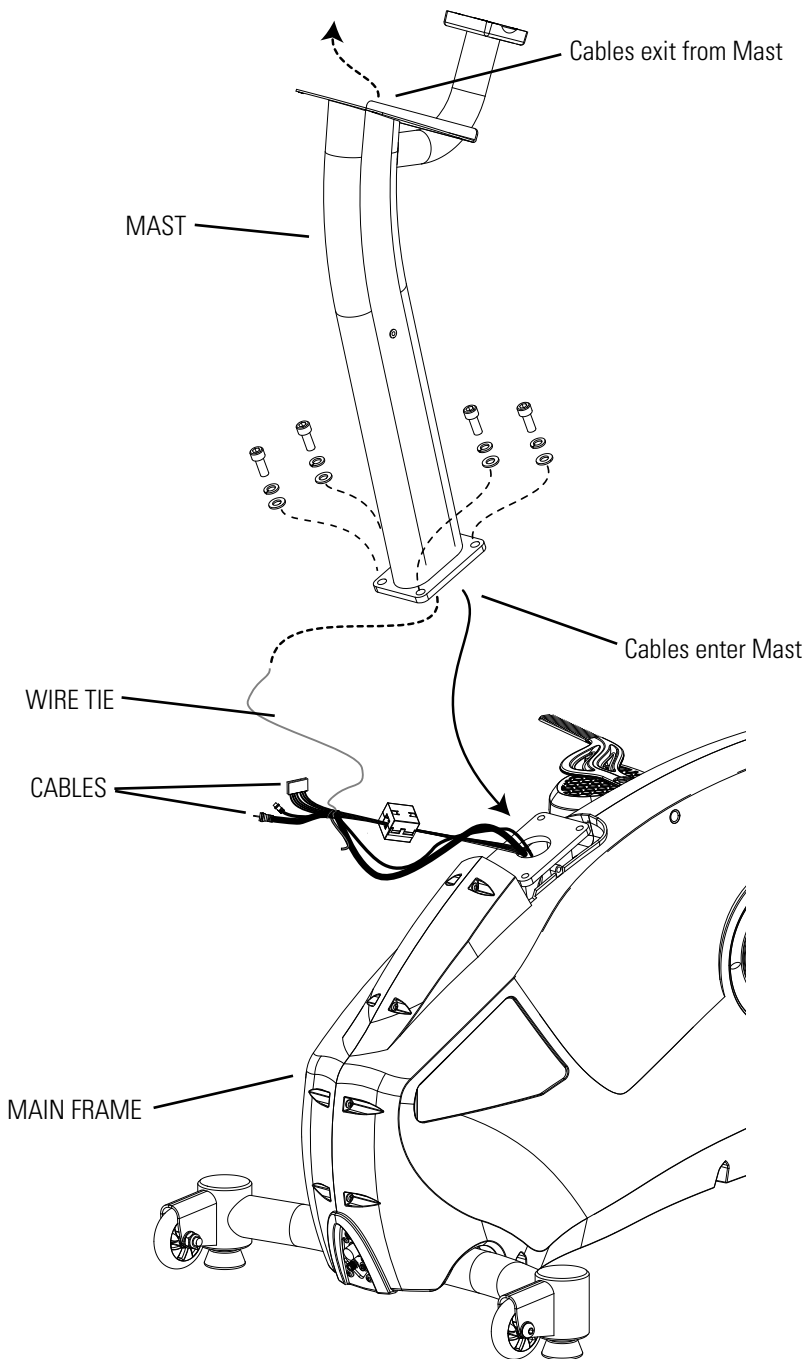

Figure 50 -

Cable Connections - U916

Routing and connector points for the main U916 cable connections are shown below. Wiring diagrams for the U916 console, handles and main power are provided in Section 2.

Main and TV Cables - Frame to Front Mast:



Connect the attached long Wire Tie to the main and TV cables and use it to pull the cables up through the Mast . Discard the Wire Tie after use.

NOTE: TAKE CARE NOT TO PINCH CABLES WHEN ASSEMBLING.

HR Cables - Handlebars to Front Mast:

Connect the attached long Wire Tie to the handlebar cables and use it to pull the cables out through the Mast. Discard the Wire Tie after use. (The main and TV cables are not shown, for clarity.)

NOTE: TAKE CARE NOT TO PINCH CABLES WHEN ASSEMBLING.

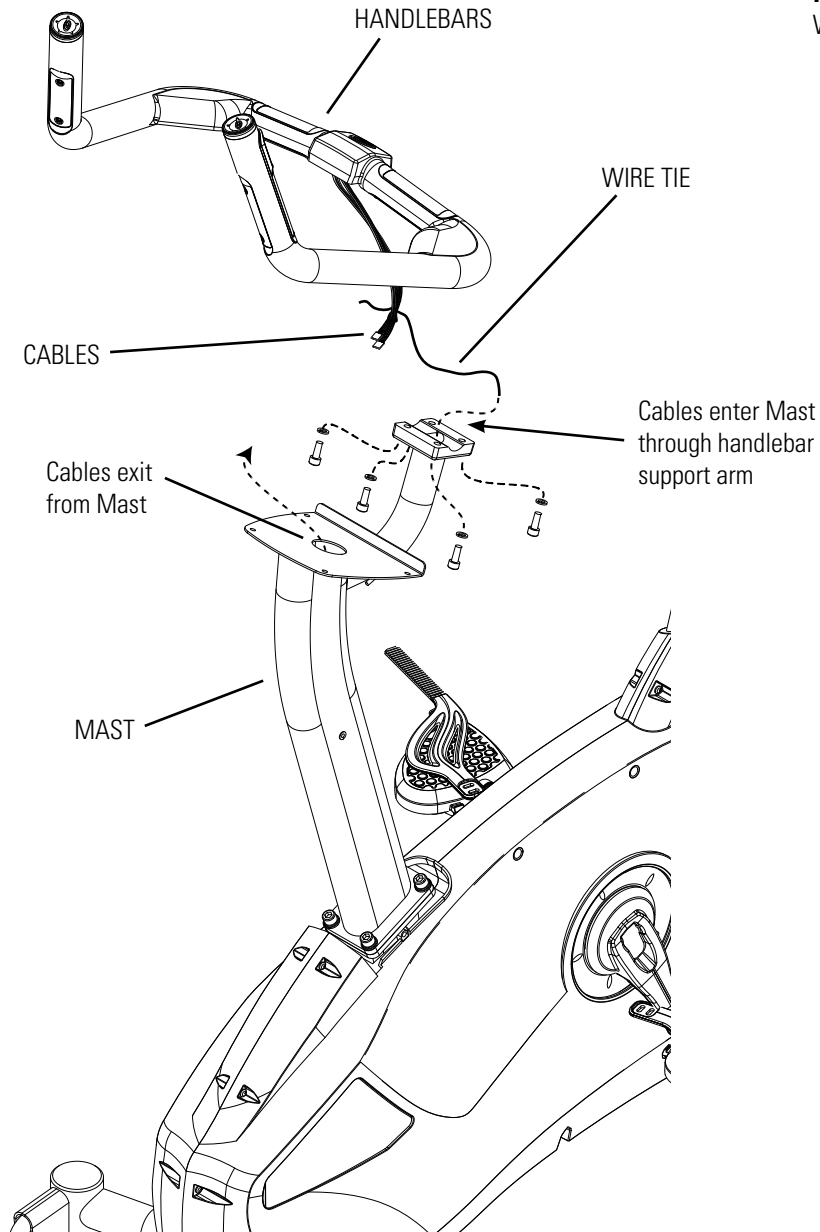

Main and HR Cables - Front Mast to Console:

Figure A - Heart Rate Wires Not Bound

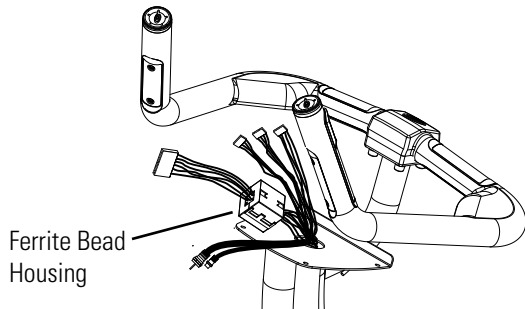
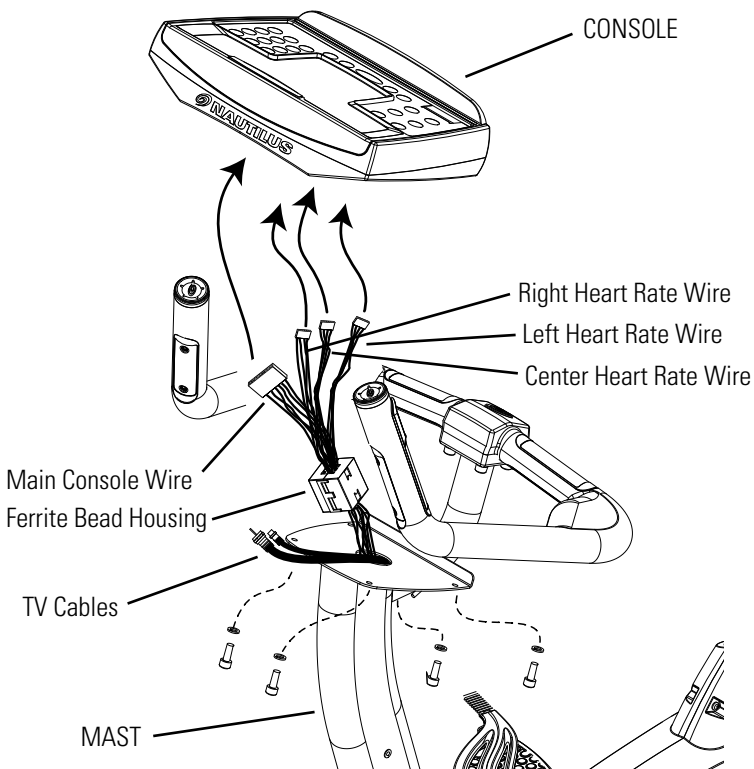
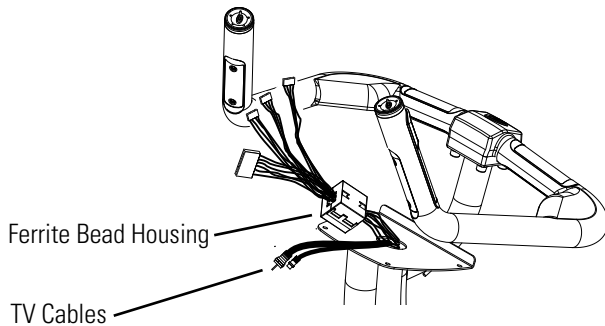

Figure B - Ferrite Bead Housing Reconnected



If the Ferrite Bead Housing is not bound around the Main Console Wire and all three Heart Rate Wires (Figure A), open the bead and reconnect it around those wires (Figure B). Confirm that all four wires are the same length before closing the bead.

Do not include the TV wires.

Plug the Main Console Wire into the large connector labeled J5 on the back of the Console.

The Right Heart Rate Wire is labeled with an "R". Plug the Right Heart Rate Wire into the connector labeled P1 on the back of the console.

Plug the Left Heart Rate Wire into the P2 connector.

Plug the Center Heart Rate Wire into the P3 connector.

Gently push the excess wires back down into the mast.

NOTE: If installing the optional LCD Monitor refer to the NV915 installation manual at this time. If not installing the LCD Monitor, wrap the end of the TV Cables with electrical tape and tuck them into the Mast.

Back of Console:

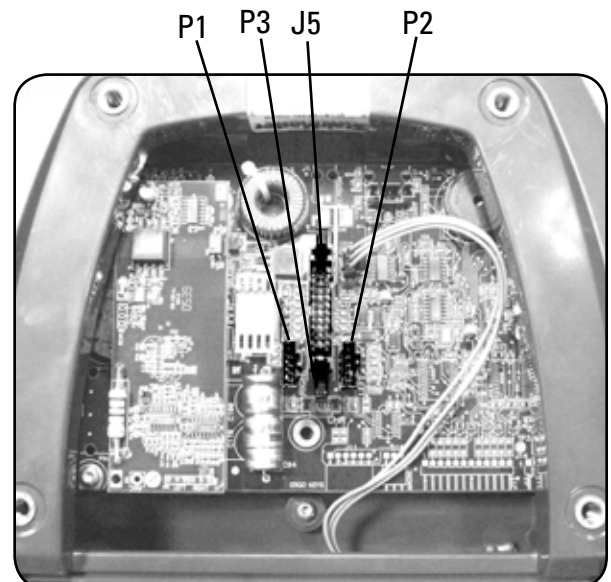

Cable Connections - R916

Routing and connector points for the main R916 cable connections are shown below. Wiring diagrams for the R916 console, handles and main power are provided in Section 2.

Main and TV Cables - Frame to Front Mast:

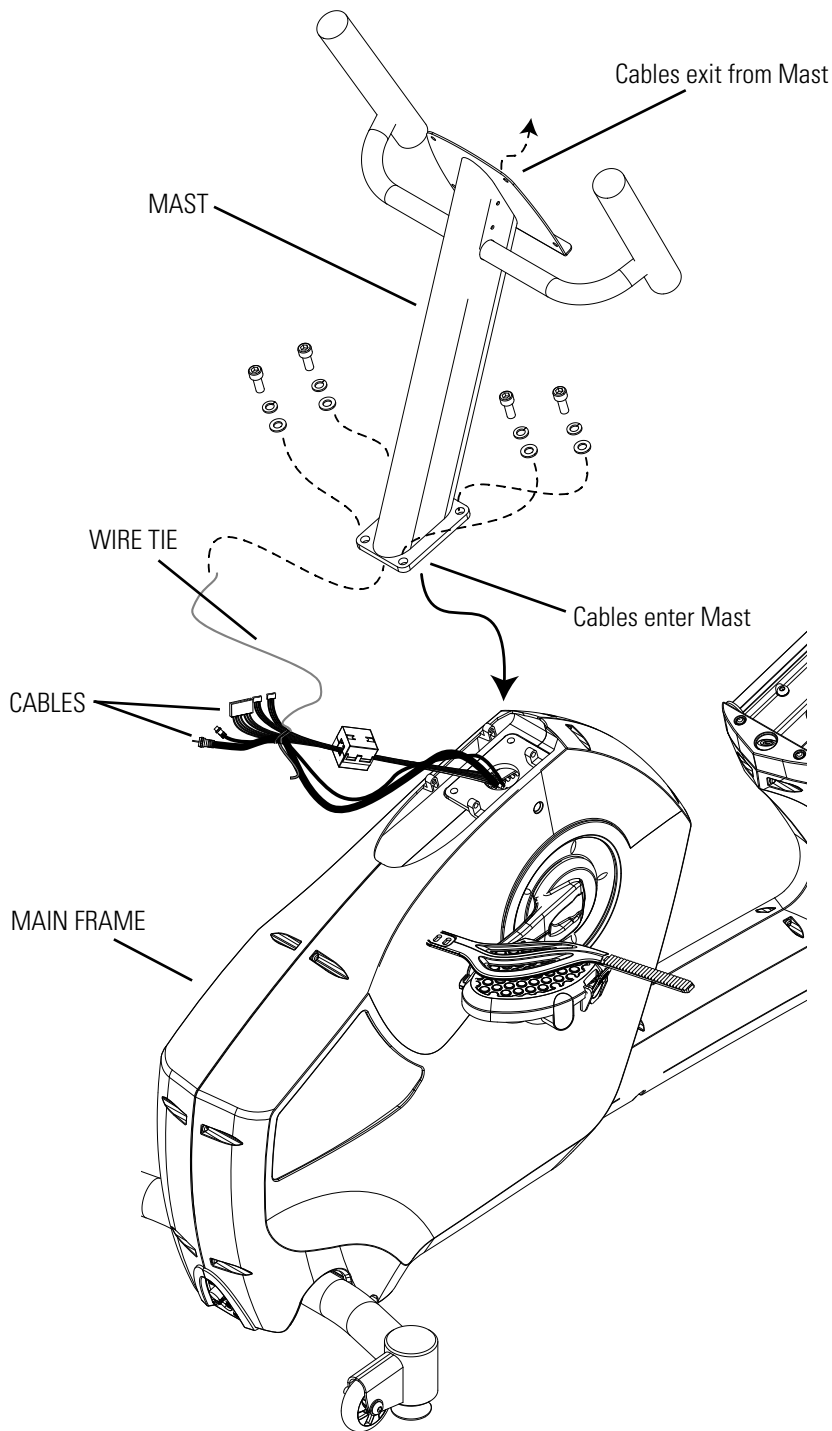

Connect the attached long Wire Tie to the main and TV cables and use it to pull the cables up through the Mast. Discard the Wire Tie after use.

NOTE: TAKE CARE NOT TO PINCH CABLES WHEN ASSEMBLING.

Mast attached to Main Frame:

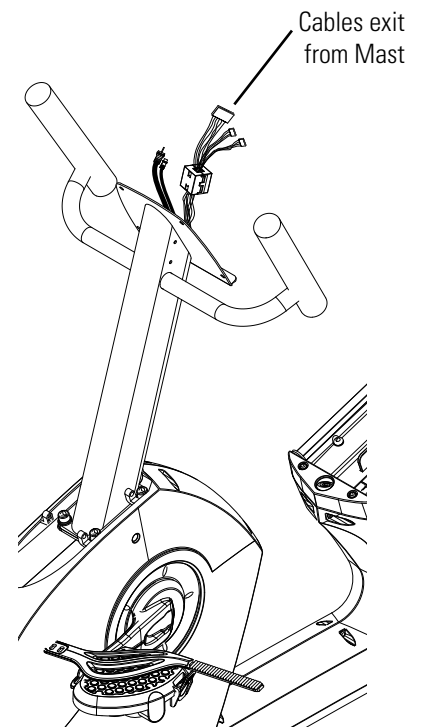

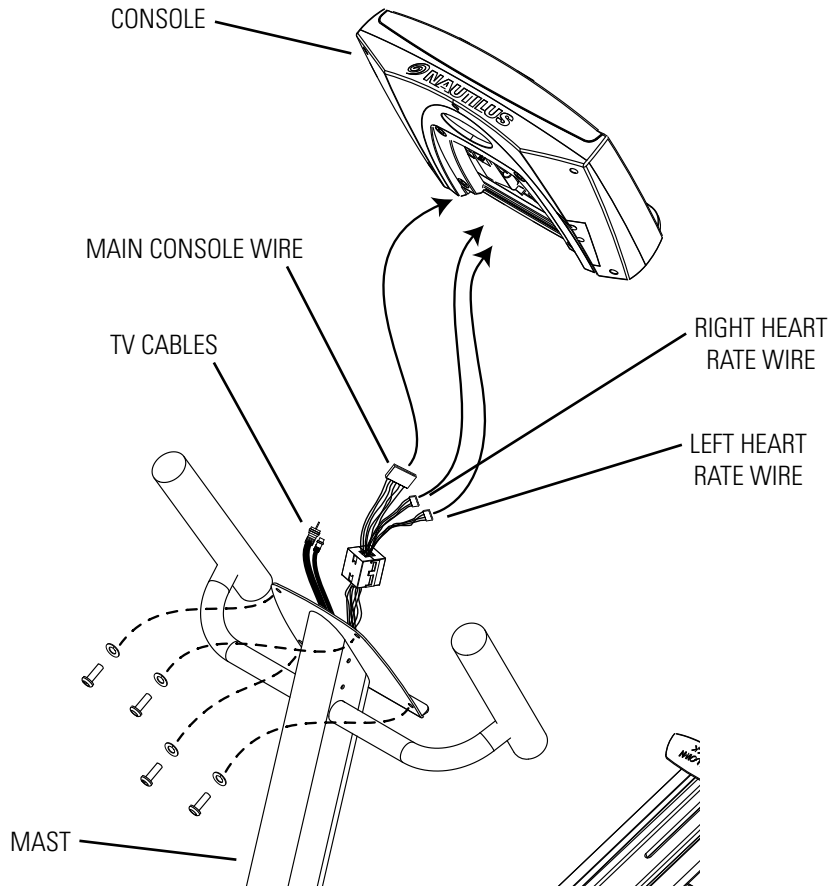
Main and HR Cables - Front Mast to Console:

Plug the Main Console Wire into the large connector labeled J5 on the back of the Console.

The Right Heart Rate Wire is labeled with an "R". Plug the Right Heart Rate Wire into the connector labeled P1 on the back of the console.

Plug the Left Heart Rate Wire into the P2 connector.

NOTE: If installing the optional LCD Monitor refer to the NV915 installation manual at this time. If not installing the LCD Monitor, wrap the end of the TV Cables with electrical tape and tuck them into the Mast.

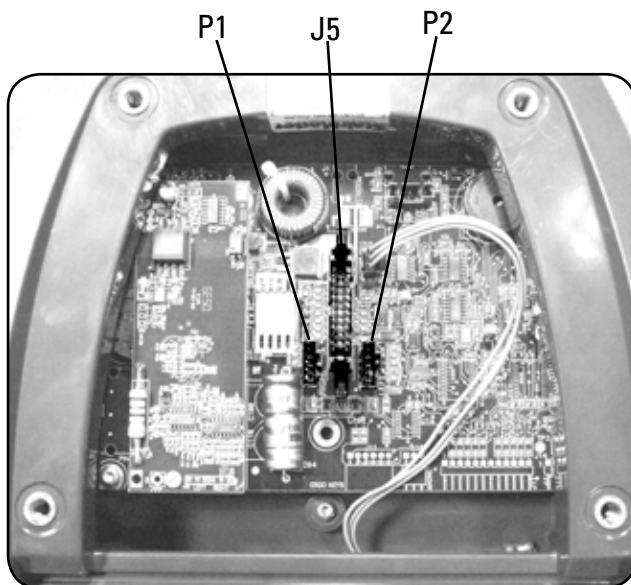
Back of Console:

HR Cables - Handlebars to Main Frame:

Carefully Align the Seat Assembly with the Seat Carriage. Connect the Heart Rate Cables from the Handlebars to the corresponding connectors exiting the Seat Carriage.

NOTE: Use caution as the Seat Assembly is not secured to the Seat Carriage. It is easier to connect the cables if the Carriage is positioned toward the bottom of the the range.

To avoid damage to the Heart Rate Cables, do not apply excessive force.

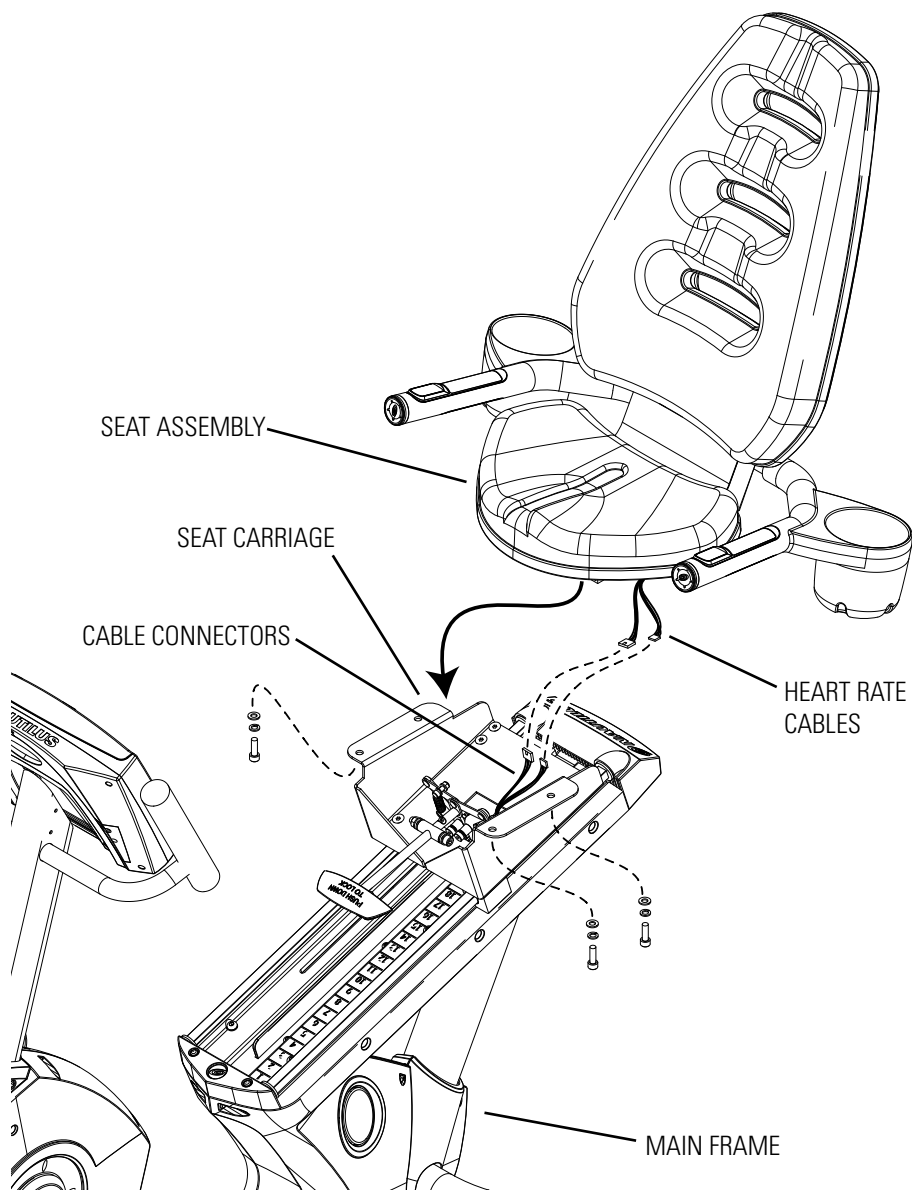

Appendixes

Contents

Appendix A—Required Tools	60
Appendix B—Using a Multimeter	61
Appendix C—International Power Plug Configurations	64

Appendix

Required Tools

This is a list of the most common tools you will need to service the R916 and U916 Bikes.

Table A–1. Required Tools and Uses

Tool	Purposes
Socket wrench	General
#0 Phillips screwdriver	General
#2 Phillips screwdriver	General
Cordless drill w/bit	General
Ratchet	General
Wire cutters	General
15mm Pedal Wrench	Removing Pedals
8mm Allen Wrench	Removing/Installing crank bolts
ISIS Crank puller	Removing Crank Arms
17mm and 19mm open end wrench	Adjusting timing belt tension
Impact cordless drill	Flywheel
3/16 Allen	Poly-V wheel
5/16 Nut driver	Resistor cable
9/16 socket	Alternator
Snap Ring Pliers	Intermediate Hub
5mm Allen Wrench	Intermediate Pulley
6mm Allen Wrench	Removing/Installing Handlebars
Multimeter	Electrical troubleshooting

Using a Multimeter

How to Use a Multimeter

This is a basic overview of multimeters. For in depth directions, please use the manual provided with your multimeter.

What Does a Multimeter Do?

A multimeter combines the functions of three instruments: ammeter (measures current), voltmeter (measures voltage), and ohmmeter (measures resistance).

Electronic signals are usually thought of in terms of voltage. For that reason, and because it is an easier measurement to take, we will use the volts setting. We will not want to use the ammeter setting to troubleshoot fitness equipment.

The ohmmeter setting is used to determine whether there is an open circuit (a bad connection or break in the wires) or a short circuit (two wires that normally would not come in contact with each other have been pinched together or crossed in some way).

Ohmmeters work by passing a small current through the wire or component and measuring the voltage produced.

Type of Multimeters

Multimeters are available in digital and analog models. Digital meters give an output in numbers usually on a LCD. Analog meters move a needle along a scale.

We recommend using a digital meter. While analog meters can be very cheap, they are difficult for beginner to read accurately, especially on resistance scales. Also, the components are delicate and easily damaged.

Settings

For the beginner the multimeter can be intimidating because of the range of settings available. The diagrams on the next page show what settings to use when checking voltage and resistance on the fitness equipment. Perhaps more importantly, it shows which settings are not needed. There are two types of digital multimeters commonly available:

- switched range and
- autoranging.

Switched range meters require you to choose the appropriate position from the many choices available on the dial. For example, if the dial is switched to 20VDC, 20 volts is the maximum voltage that can be measured. This is important when you want to read small increments in voltage accurately. For example, if the required voltage is 13.5 volts and the meter is set too high, you may only see 13 volts on the readout. Setting the meter to a lower maximum will show 13.5 volts.

Appendix

Autorangeing meters automatically adjust the range to give an accurate reading. This type of meter is more expensive but much easier to use.

Switched Range Meter

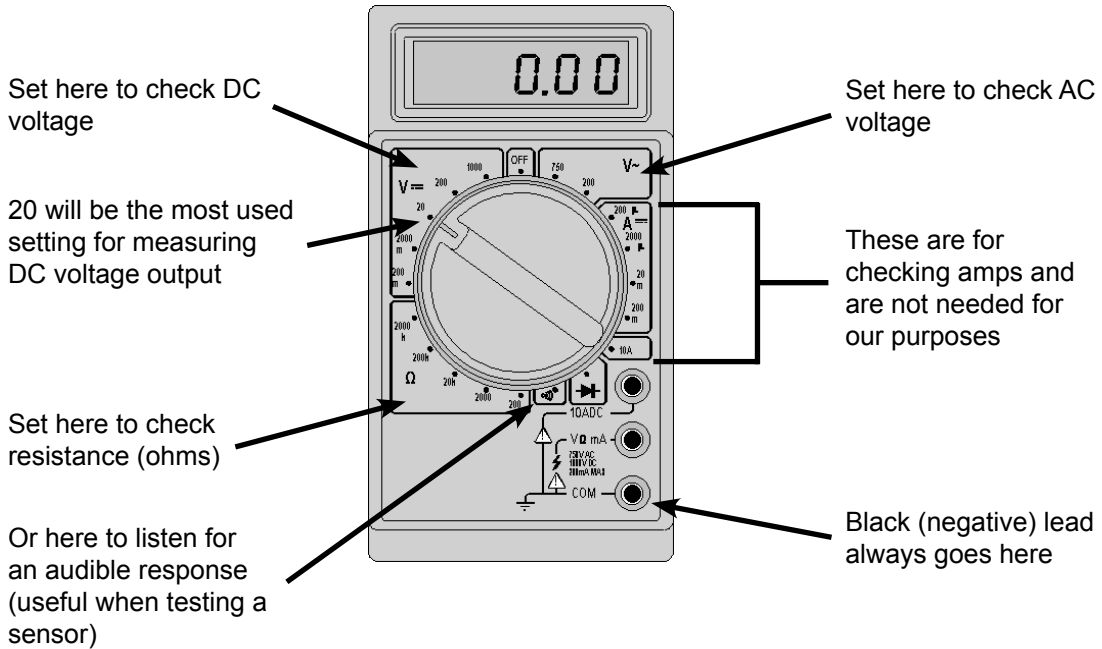

Autorangeing Meter

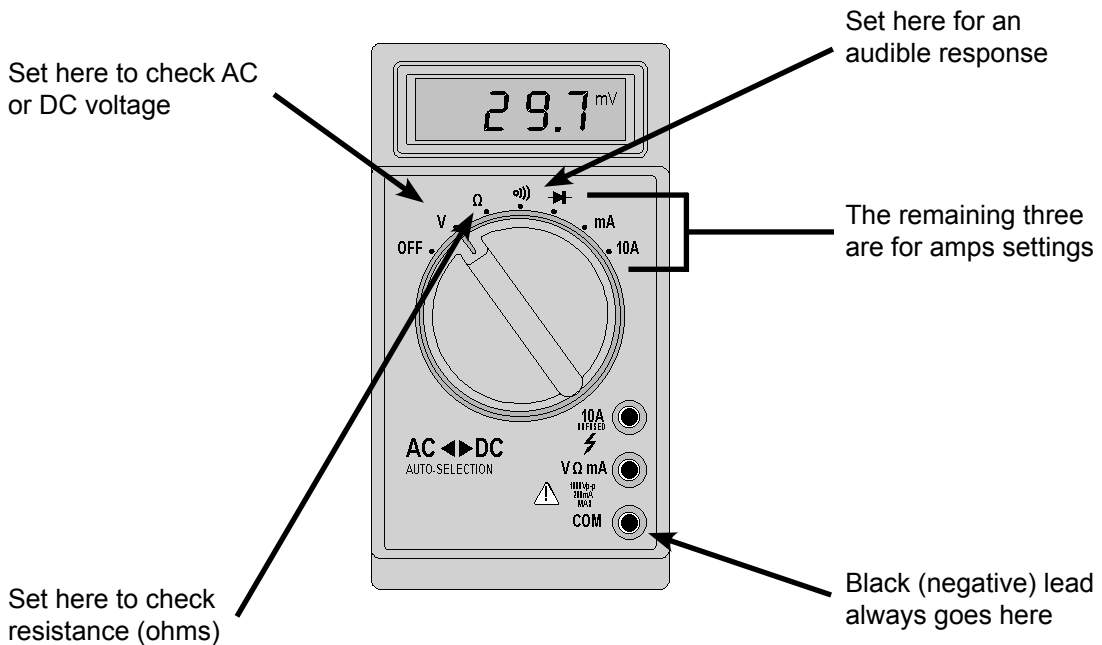

Checking Resistance

Use this procedure to check for broken wires:

- 1 Set the multimeter to the lowest OHMs (resistance) range.
 - 2 Attach the test leads on both ends of the wire being tested.
 - 3 Observe the reading.
- A *short* circuit will read less than approximately 3 ohms. This is the correct reading for an undamaged wire.
 - An *open* circuit will usually read infinite; on a digital meter it will have an error code. This signals a broken or cut wire.

Use this procedure to test for crossed wires. In most circumstances all individual wires in a cable will be insulated from each other. When a wire is pinched, it becomes short circuited to an adjacent wire. This can cause problems resulting in blown fuses or *fried* components.

- 1 Set the multimeter to the lowest OHMs (resistance) range.
- 2 Attach one test lead of the multimeter to one wire and check all adjacent wires. This can all be done at one end of the cable. However, the other end of the cable must be disconnected from the circuit board. All wires should be insulated from each other and therefore test open.
- 3 Observe the reading.

Checking Voltage



Use this procedure to check voltage output:

- 1 Determine whether the voltage is AC or DC voltage, and choose the appropriate setting on the multimeter.
- 2 Set the multimeter to the lowest setting that is still higher than the highest output of the component being tested.
- 3 Place the black and red leads or probes on the appropriate corresponding wires, pins, or connectors.
- 4 Observe the reading, and proceed according to the troubleshooting sections in this manual.

Appendix

International Power Plug Configurations

Table B-1. International Power Plugs

Power Cords	System	Country
	G	UK
	C, E, F	Europe
	J	Swiss
	K	Australia
	L	

Commercial Market Warranty Information

All Nautilus® exercise products are warranted to the commercial market purchaser to be free from defects in materials and workmanship. Warranty coverage valid to the original purchaser only and proof of the purchase will be required. Any product sold or placed in an application not recommended by Nautilus will void any warranty coverage set forth by Nautilus warranty policies and procedures.

Time Period

15 Years - Frame

3 Years- Mechanical and electrical parts

1 Year- Labor

1 Year - Wear items

Warranty terms may differ outside the USA.

What this warranty does not cover

1. Users weighing more than 400 lbs (182 kg).
2. Any damage, failure or loss caused by accident, misuse, neglect, abuse, improper assembly, improper maintenance or failure follow instructions or warnings in Owner's Manual.
3. Use of product in a manner or environment for which it was not designed.

Limitations

The foregoing warranties are in lieu of and exclude all other warranties not expressly set forth herein, whether expressed or implied by operation of law or otherwise, including, but not limited to, warranties of merchantability or fitness for a particular purpose. Nautilus shall in no event be liable for incidental or consequential losses, damages or expenses in connection with its exercise products. Nautilus' liability hereunder is expressly limited to the replacement of goods not complying with this warranty or, at Nautilus' election, to the replacement

amount of the purchase price of the exercise product in question. Some states do not permit the exclusion or limitation of implied warranties or incidental or consequential damages, so the preceding limitations and exclusions may not apply to you.

Procedures

Warranty service will in most cases be performed by an authorized Nautilus Fitness Dealer or Service Technician. The original purchaser must provide proof of purchase, Service calls and/or transportation to and from the Nautilus Dealer is the responsibility of the purchaser.

1. Nautilus will have the option to repair or replace any exercise product, which requires service.
2. Nautilus will replace any equipment frame that is structurally defective with a new frame or replace the unit with a unit of equal value.
3. Nautilus is not responsible for dealer labor charges for the component changeovers completed after the labor related warranty period stated herein.
4. If you elect to repair an exercise product or part yourself, using the services of someone other than an authorized Nautilus Fitness Dealer or Service Technician, or use a replacement part not supplied by Nautilus, Nautilus shall not be liable for any cost, damage, failure or loss caused by the use of such unauthorized service or parts.

IMPORTANT CONTACT NUMBERS

If you need assistance, please have both the serial number of your machine and the date of purchase available when you contact the appropriate Nautilus office listed below.

WORLDWIDE CUSTOMER SERVICE

• NORTH AMERICA OFFICE

Nautilus, Inc.
World Headquarters
16400 S.E. Nautilus Drive
Vancouver, Washington, USA 98683
Phone: 800-NAUTILUS (628-8458)
Fax: 800-686-6466
e-mail: cstech@nautilus.com

• CORPORATE HEADQUARTERS

Nautilus, Inc.
World Headquarters
16400 S.E. Nautilus Drive
Vancouver, Washington, USA 98683
Phone: 800-NAUTILUS

• CANADA OFFICE

Nautilus Fitness Canada, Inc.
925 Keewatin Street
Winnipeg, MB, Canada R2X 2X4
Phone: 866-381-5996
Fax: 800-532-6934
e-mail: nfcpartsandservice@nautilus.com

INTERNATIONAL CUSTOMER SERVICE

• INTERNATIONAL OFFICE

Nautilus International S.A.
Rue Jean Prouvé 6
1762 Givisiez / Switzerland
Tel: +41-26-460-77-77
Fax: +41-26-460-77-70
E-mail: technics@nautilus.com

INTERNATIONAL OFFICES:

• SWITZERLAND OFFICE

Nautilus Switzerland S.A.
Tel: +41-26-460-77-66
Fax: +41-26-460-77-60

• GERMANY and AUSTRIA OFFICE

Nautilus GmbH
Tel: +49-2203-2020-0
Fax: +49-2203-2020-45

• ITALY OFFICE

Nautilus Italy s.r.l.
Tel: +39-51-664-62-01
Fax: +39-51-664-74-61

• UNITED KINGDOM OFFICE

Nautilus UK Ltd.
Tel: +44-1908-267-345
Fax: +44-1908-267-346

• CHINA OFFICE

Nautilus Representative Office
Tel: +86-21-523-707-00
Fax: +86-21-523-707-09



Model U916



Model R916



Be Strong.™

For more information about our Commercial Series exercise machines or other Nautilus® equipment for your home, visit www.Nautilus.com.

© 2006 Nautilus, Inc. All rights reserved. Nautilus, the Nautilus Logo, ROC, Remote Operation Control, Be Strong, StairMaster and StepMill are either registered trademarks or trademarks of Nautilus, Inc. All others are trademarks of their respective company.

Nautilus, Inc. World Headquarters, 16400 SE Nautilus Drive, Vancouver, Washington, USA 98683, 1-800-628-8458, www.Nautilus.com.